

VENTING THE WATER HEATER

The purpose of venting a gas or oil-fired water heater is to completely remove all products of combustion and to vent gasses to the outside air without condensation in the vent or spillage at the draft hood (except in cases of downdraft or poor stack conditions).

To assure correct venting, use a strong, gas-tight insulated pipe with a cross section equal to that of the flue collar or draft hood outlet and of sufficient vertical height.

During vent installation, avoid sharp turns, long horizontal runs and improper pitches. Maintain proper support of vent connectors and joints, observe clearances from all combustibles, and top the vent outlet with an approved cap.

Type "L" vent is double walled vent. Type "L" is stainless lined and used for oil and Power Gas heaters. Type "B", due to its temperature rating, can only be used with atmospheric gas water heaters.

All venting installations must conform with local codes. In the absence of local codes, refer to "National Fuel Gas Code" NFPA 54 and "Standard for the Installation of Oil-burning Equipment" NFPA 31 (Tables 21-33 are based on NFPA 54).

Note: Fan min. and max. applies to oil and power gas heaters; nat. max. refers to vent hood-equipped appliance.

TYPES OF VENTING

Natural Draft: The venting of combustion products through a venting system (vent piping) and chimney by natural means.

Induced Draft: A power operated fan, blower or other mechanical device installed in the chimney connector (vent piping) between the appliance and chimney to increase natural draft (rarely used since the advent of high speed flame retention burners).

Power / Sidewall Venting: A combination of a mechanical fan (power venter), air pressure switch, post-purge control (timed or temperature), barometric damper and flue connectors designed to exhaust combustion gases through the side wall of a structure to the outside atmosphere in lieu of a chimney.

Figure 21: Single Water Heater Venting

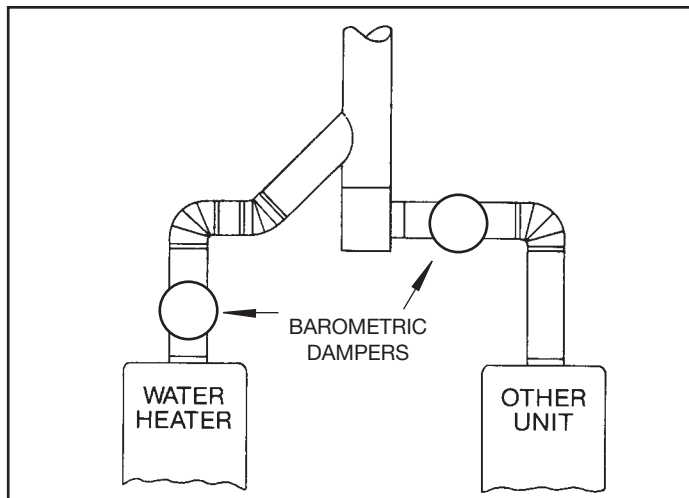

Sealed Combustion / Balanced Flue: A system consisting of an appliance specifically designed, constructed and installed so all air for combustion is derived from the outside atmosphere and all flue gases are discharged to the outside atmosphere.

INDIVIDUAL VENTS

An "individual" vent is defined as a single independent vent for one appliance. "Total Vent Height" is the measured vertical distance between the flue outlet and the vent top. The position or rise of a connector – or the location of an offset – has no effect on the "Total Vertical Height." "Length of Lateral" is the horizontal distance or offset between the flue outlet and the final vertical portion of the vent. See Figure 21.

Figure 22: Typical Individual Venting

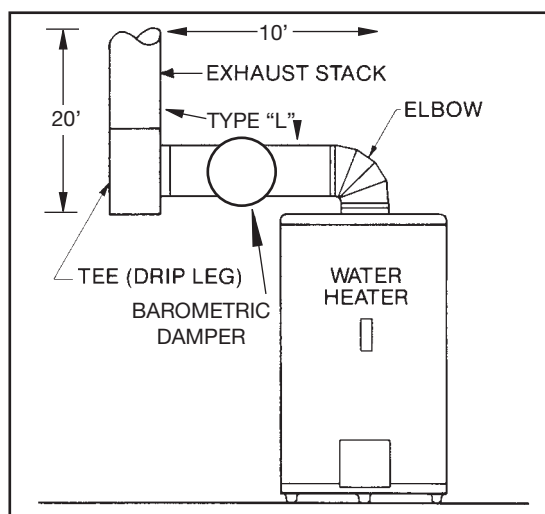

Using the Individual Vent Tables

To determine the proper vent size for an individual vent, use Tables 21-25, pages 44-49 (depending on vent type).

Example: A typical individual venting project is shown in Figure 22. The Power Gas water heater has a 200,000 BTUH capacity, and a 6" flue.

To determine the size of the vent, go down the Total Vent Height column (Table 21, page 44) to the 20' height, then across to the right on the line for 10' lateral. 62,00 BTUH min. and 351,000 BTUH max. capacity is shown in the 6" fan min/max column. This system should work fine.

Vent Reductions

The vent size determined by Tables 21-33, pages 44-56 may be used as long as the vent is at least 10' high. When a vent is shorter than 10', the vent should be at least as large as the flue. Vents for draft hoods 12" in diameter or less should not be reduced more than one pipe size. A six-to-five inch, or a twelve-to-ten inch reduction is a one pipe size reduction. For larger gas-fired equipment, such as boilers having draft hood sizes from 14" to 24" diameters, reduction of more than two pipe sizes is not recommended (24-to-20 inches is a two-size reduction).

THE COMMON VENT

A “combined” vent is a venting system for two or more appliances at one level that are attached to a common vent.

Least Total Height is the vertical distance from the highest appliance flue outlet in the system to the top of the vent (see Figure 23). This is one fixed dimension for any one system, regardless of the number or placement of appliances in the system.

Connector Rise for any appliance is the vertical distance from its flue outlet to the point where the next connector joins the system.

A **Common Vent** is the portion of the venting system above the lowest interconnection. L-venting is typically used for gas and oil. B-venting may be used for gas only where permitted by local codes. Both are double wall vents. “L” vent uses a stainless steel liner; “B” vent uses an aluminum liner.

Using the Common Vent Tables

DETERMINING EACH VENT CONNECTOR SIZE:

1. Determine the Least Total Height for the system.
2. Determine the Connector Rise for each appliance.
3. Enter the Vent Connector Tables (Tables 27-30) at the appropriate Least Total Height. Continue across to the right on a line for the first appliance Connector Rise to the name plate BTUH rating (or the next higher rating) for that appliance. Read the connector vent size for that appliance at the top of the column.
4. At the Least Total Height, repeat the procedure for the Connector Rise and BTUH rating for each appliance.

Caution: Never use a connector smaller than draft hood outlet size.

DETERMINING THE SIZE OF A COMMON VENT:

1. Add together all appliance BTUH input ratings to determine the total BTUH rating.
2. Enter the Common Vent Tables (Tables 27-30) at the Least Total Height.
3. Continue across to the right; stop at the first value which is equal to or greater than the total BTUH rating.
4. Read the size of the common vent at the top of the column.

Caution: Regardless of the table results, the common vent must always be at least as large as the largest connector. If both connectors are the same size, the common vent must be one size larger.

Example: Figure 24 shows a typical two-appliance combined vent and relative individual connector sizes. Use the following procedure:

- A. Enter the Vent Connector Table (Table 27) at the Least Total Height of 15 feet, and a Connector Rise of one foot. Read across to the BTUH rating for natural gas heaters next higher than the water heater rating. This is the column showing 53,000 BTUH. At the top of this column, a four inch connector size is designated for the water heater. See Figure 22, Drawing 1.
- B. Enter the Vent Connector Table again, this time at the same Least Total Height of 15 feet, but for the furnace Connector Rise of three feet. Read across to 111,000 BTUH or the next higher rating above 105,000 BTUH. At the top of this column a vent connector size of five inches is designated for the furnace connector. See Figure 19, Drawing 2.
- C. The sum of the two ratings is 140,000 BTUH. Enter the Common Vent Table at the same Least Total Height of 15 feet and look in the natural gas column. For a total capacity of 144,000 BTUH, the column heading directs the use of a five inch common vent for this system. See Figure 24, Drawing 3.

Figure 23: Dual Water Heater Venting

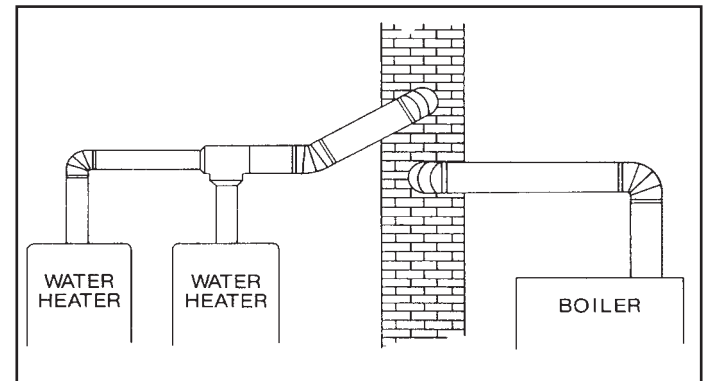
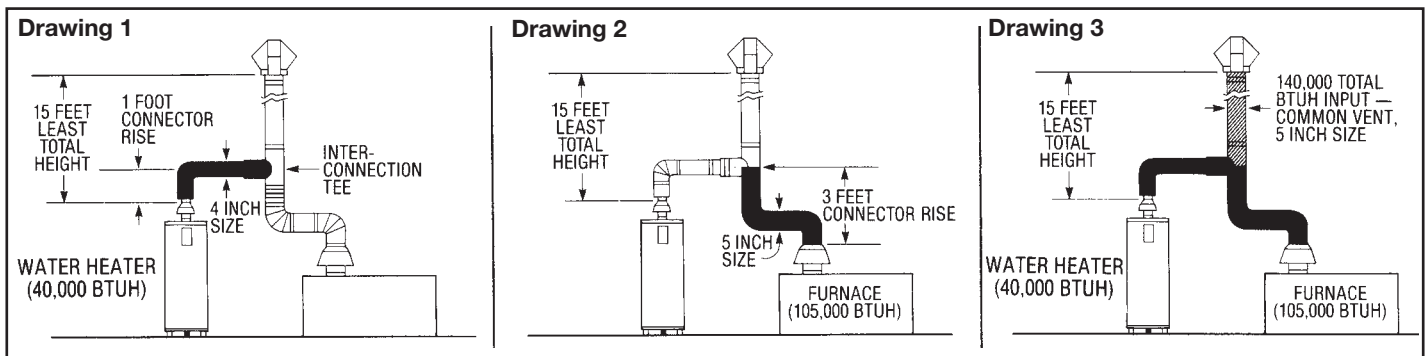

Figure 24: Determining the use of a 5” common gas vent



COMBUSTION AND VENTILATION AIR

Properly sized vents are vital for the safe and efficient operation of a Bock water heater installed in a confined space. When combustion and ventilation air are supplied from inside the building, each opening must have an area of one square inch for every 1,000 BTUH input. When combustion air is supplied from the outside, each opening must have an area of one square inch for every 2,000 BTUH for horizontal ducts and one square inch for every 4,000 BTUH for vertical ducts (refer to NFPA 31, 54).

The Bock BCS is exempt from these requirements because all combustion air is supplied from outside the heated space (however, some air for ventilation is desirable),

Most oil burners and some Power Gas burners can also be equipped with outside air kits (available from the burner

manufacturer) that draw combustion air from the outside through a duct system. This eliminates the need the supply combustion air through louvered ducts as described previously (ventilation air is still required). Air may also be required for draft hood or barometric damper operation.

As an alternative, combustion air may be supplied by a powered blower system such as a Field "Fan in a Can" or Tjernlund "In-forcer." These systems are powered on a call for heat, and force outside combustion air into the room through their own duct system. These systems, when properly sized, eliminate the need for any other combustion air ducting to the outside or other parts of the building. Consult the manufacturer of these systems for installation information and sizing.

BALANCED COMBUSTION SYSTEM (BCS)

Flue outlet placement is of utmost importance for maximizing the performance of the Bock Balanced Combustion System (US patent # 5,924,390).

BALANCED FLUE™

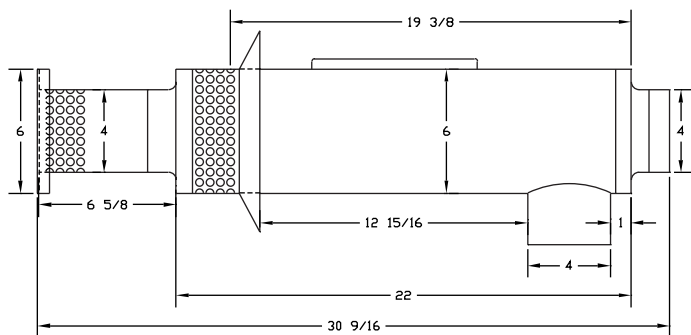

The east or south wall (or wall opposite of prevailing winds) is the preferred wall for installation if prevailing winter winds are typically out of the north or west. This reduces the likelihood that the Balanced Flue™ application will be operating against high winds and severe cold when it is cycling the most often.

The flue outlet must be placed at least one (1) foot above the highest anticipated snow load to prevent flue blockage.

Use a flat wall for the flue outlet and stay a minimum of four feet from corners or any structure to reduce eddy currents.

To reduce frosting effects, place the outlet **as far as possible** from windows and doors – four feet is a minimum (per NFPA 31 A-1-12.3).

A minimum distance of three feet from the outlet to plants and shrubs is suggested; a greater distance is preferred, as the moisture and frost effects can result in damage or loss.

1. Cut a 7" O.D. opening in the preferred wall and provide a minimum of 1/2" clearance of non-combustible space around the Balanced Flue™. The opening should allow for a 1/2" downward pitch to the outside for drainage of any condensate in the Balanced Flue™.

2. Insert the Balanced Flue™ from the inside through the wall and fasten to the inside wall with the tabs provided. Check the outside extension to be sure air inlet holes are exposed. On the outside wall, install the flashing ring provided. Caulk around the outer rim of the flashing ring to prevent moisture from entering through the wall.

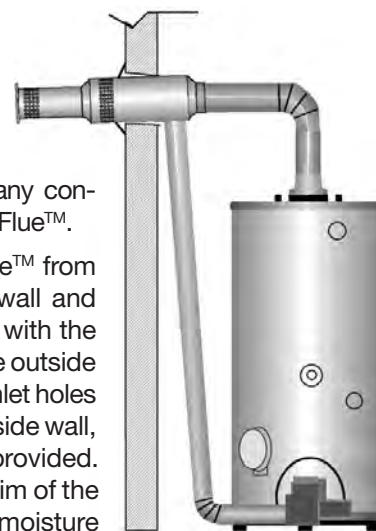

* INSUFFICIENT OR EXCESSIVE DRAFT (NATURAL & POWER VENT)

Excessive or insufficient draft can cause poor burner performance, excessive combustion noise and improper combustion or sooting. On Bock products, stack draft should be a minimum of -0.02" W.C. and a maximum of -0.05" W.C. where there is insufficient draft, install the properly sized draft inducer. Where excessive draft is encountered, install

the properly sized barometric draft regulator. **Note:** All Power Gas heaters must use a barometric damper.

For sizing and technical information on draft inducers and diverters, please contact the manufacturer of the equipment: Field Controls Co., 252/522-3031 or Tjernlund Products, Inc., 800/255-4208.

* Does not apply to BCS applications.

* BAROMETRIC DRAFT CONTROLS (NATURAL & POWER VENT)

Barometric draft controls and draft inducers can be used to correct draft problems found in some applications. A barometric draft control will bring room air into the vent to decrease the draft and a draft inducer will help force air away from the appliances.

Barometrics should be installed on all Bock power gas and dual fuel heaters to fine tune the equipment for optimal efficiency. A barometric is not used on Bock atmospheric gas heaters equipped with draft hoods.

* Does not apply to BCS applications.

TABLE 19A

POWER VENT SELECTION – TJERNLUND PRODUCTS

GPAK/HS-SERIES (Residential/light commercial)

MODEL #	VENT PIPE DIA.	BUT/HR INPUT	MAXIMUM PIPE LENGTH (FT) AT STACK TEMP			CFM @ 70°F				
			GAS FIRED 300°F	400°F	OIL FIRED 500°F	0" SP	.50" SP	.75" SP	1.0" SP	1.4" SP
HSUL-J HST-J ** HS115-J GPAK-J GPAK-JT	4"	50,000 75,000 100,000 125,000	100' 100' 100' 35'	100' 100' 100' 23'	100' 100' 100' -	110	85	67	10	-
HSUL-1 HST-1 HS115-1 GPAK-1 * GPAK-17*	4" 6"	150,000 200,000 250,000 300,000 150,000 200,000 250,000 300,000	100' 87' 40' 4' 100' 100' 100' 30'	60' 57' 12' - 100' 100' 100' -	35' 27' - - 100' 100' 100' -	158	115	95	12	-
HSUL-2 HST-2 ** HS115-2	6" 8"	350,000 400,000 450,000 500,000 550,000 600,000 350,000 400,000 450,000 500,000 550,000 600,000	100' 100' 100' 100' 94' 15' 100' 100' 100' 100' 100' 67'	100' 100' 100' 72' - - 100' 100' 100' 100' - - -	100' 100' 67' - - - 100' 100' 100' 100' 100' 100' -	286	235	215	196	158

HS-3, 4, 5 SERIES (Commercial)

MODEL #	VENT PIPE DIA.	BUT/HR INPUT	MAXIMUM PIPE LENGTH (FT) AT STACK TEMP		CFM @ 70°F				
			100% Dilution 300°F GAS FIRED Atmospheric w/Draft Hood or Draft Diverter	25% Dilution 400°F GAS FIRED Power Burner w/Barometric	0" SP	.50" SP	.75" SP	1.0" SP	1.4" SP
HS-3	8"	450,000	100'	100'	500	425	380	325	110
		500,000	100'	100'					
		600,000	100'	100'					
	700,000	7'	100'						
	10"	450,000	100'	100'					
		500,000	100'	100'					
600,000		100'	100'						
HS-4	8"	700,000	100'	100'	925	800	730	620	425
		800,000	100'	100'					
		900,000	100'	100'					
		1,000,000	70'	100'					
		1,100,000	32'	100'					
		1,200,000	5'	100'					
	10"	700,000	100'	100'					
		800,000	100'	100'					
		900,000	100'	100'					
		1,000,000	100'	100'					
		1,100,000	97'	100'					
		1,200,000	14'	100'					
12"	700,000	100'	100'						
	800,000	100'	100'						
	900,000	100'	100'						
	1,000,000	100'	100'						
	1,100,000	100'	100'						
	1,200,000	34'	100'						
HS-5	10"	1,200,000	100'	100'	925	800	730	620	425
		1,400,000	100'	100'					
		1,600,000	100'	100'					
		1,825,000	29'	100'					
		1,200,000	100'	100'					
		1,400,000	100'	100'					
	14"	1,600,000	100'	100'					
		1,825,000	72'	100'					
		1,200,000	100'	100'					
		1,400,000	100'	100'					
		1,600,000	100'	100'					
		1,825,000	100'	100'					

VH1 SERIES VENT HOODS

MODEL	DIMENSIONS							ROUGH-IN DIMENSIONS
	A DIA.	B	C	D	E	F	G	
VH1-3"	3"	6 1/4" SQ.	8 1/2"	10"	10"	5 1/4"	7 3/4"	6 3/4" SQ.
VH1-4"	4"	7 1/2" SQ.	7 1/8"	13"	8 5/8"	7 3/8"	11"	8" SQ.
VH1-6"	6 1/2"	8 1/2" DIA.	7 7/8"	12"	9 1/2"	10 1/2"	10"	9" DIA.

MODEL	DIMENSIONS				ROUGH-IN DIMENSIONS	
	A DIA.	B	C	E		
VH1-8"	8"	15 1/4"	9"	18 3/8"	20"	8 1/2" DIA.
VH1-10"	10"	15 1/4"	9"	18 3/8"	20"	10 1/2" DIA.

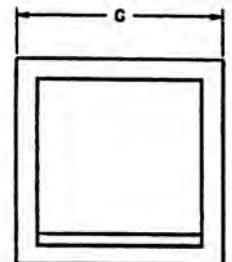
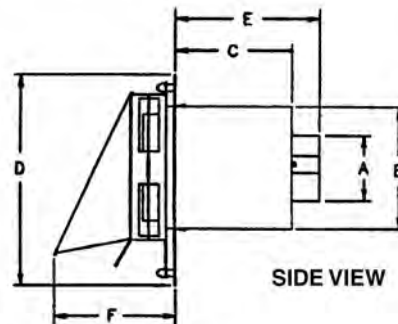
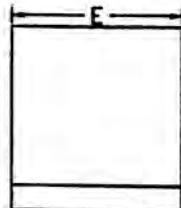
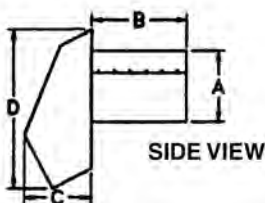

TABLE 19B

POWER VENT SELECTION – FIELD CONTROLS

MODEL	MAX. OIL GPH INPUT	MAX. BTUH INPUT	Max. Equivalent Feet of Vent Pipe		VENT PIPE SIZE
			at MAX. BTUH INPUT	60% of MAX. BTUH INPUT	
SWG-3	N/A	70,000	21	80	3"
			50	100	4"
SWG-4 HD	1.10	170,000	—	23	3"
			35	100	4"
			65	100	5"
SWG-5	1.85	290,000	16	44	4"
			51	100	5"
			95	100	6"
SWG-6	2.65	416,000	28	78	5"
			68	100	6"
			100	100	7"
SWG-7	3.60	566,000	28	78	6"
			61	100	7"
			90	100	8"
SWG-8	4.75	740,000	26	72	7"
			51	100	8"
			70	100	9"

MODEL	DIA.	Max. Equivalent Feet of Vent Pipe GAS BTUH Input			
		25,000	55,000	70,000	100,000
PVG-100	3"	270	100	—	—
PVGPAK-100*	4"	455	169	144	100
PVG-300	DIA.	100,000	145,000	220,000	310,000
	4"	305	145	64	—
PVGPAK-300*	5"	—	247	100	54
	6"	—	334	147	74
PVG-600	DIA.	145,000	220,000	310,000	400,000
	5"	413	181	91	54
	DIA.	310,000	400,000	520,000	610,000
	6"	146	87	52	—
	8"	216	134	86	66

* PVG PAKs include a Power Venter, 4" MG-1 Draft Control and 4" vent hood.

MODEL	DIA.	Max. Equivalent Feet of Vent Pipe OIL GPH Input			
		0.75	1.00	1.50	2.25
PVO-300	4"	287	150	75	—
	5"	—	257	120	51
	6"	—	346	172	70
PVO-600	DIA.	1.00	1.50	2.25	3.00
	5"	428	212	86	46
	DIA.	2.25	3.00	3.75	4.00
	6"	143	74	51	—
	8"	211	116	84	77

THE DRAFT INDUCER

To adjust air flow on *Tjernlund Products, Inc.** draft inducers, manually bend the draft adjustment plate until desired draft is obtained. For all models, loosen the nut and adjust the position of the draft adjustment plate until desired draft is obtained.

A *Field Controls Company*** barometric draft control should be installed on Bock Power Gas water heaters to fine tune the desired draft at the water heater. A barometric draft damper is not recommended on Bock oil-fired water heaters unless excessive draft is encountered; $-.07$ W. C., or greater.

Seal all pipe joints and seams on the pressure side of the inducer with a high temperature silicone adhesive sealant or equivalent. **Note:** A barometric draft control is not normally required on Bock gas-fired water heaters equipped with draft hoods. Before operating, run draft inducer through two or three cycles to insure proper installation.

* *Tjernlund Products, Inc., 1601 9th St., White Bear Lake, MN 55110, 651/426-2993 or 800/255-4208.*

** *Field Controls Company, 2630 Airport Road, Kinston, NC 28504, 252/522-3031.*

Installation

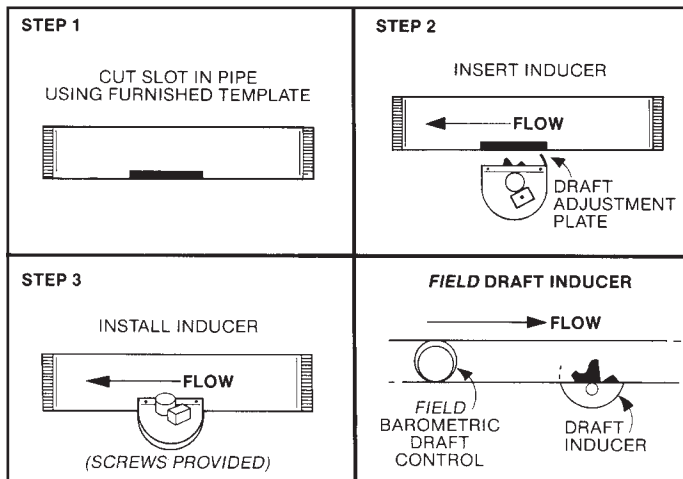

FIGURE 25: Inducer mounted vertically

