



Submittal Sheet

OptiTherm® Water Heater
300,000 to 500,000 BTU/hr

Job Name _____

Location _____

Arch./Engr. _____

Wholesaler _____

Mech. Contractor _____

Model No. _____

Gas Type _____

BTU/hr Input _____

Recovery Rate in GPH _____ °F Rise

Notes _____

Construction ASME _____ Standard _____

OptiTherm® for Optimal Thermal Efficiency:

- Maximum inputs from 300,000 to 500,000 BTU/hr
- Up to 6:1 turndown ratio
 - Fully modulating from as low as 80,000 BTU/hr
- 119/125 gallon capacities
- Up to 99% thermal efficiency
- **NEW** Front venting
- **NEW** Minimum gas supply pressure 3.5" WC (NAT) and 8" WC (LP)
- Automatic cathodic corrosion protection system
 - No sacrificial anode rods
- PVC/CPVC/ABS venting - 240' maximum power vent length
- LCD user interface with optional BMS interface
- Ecomate® insulation
- Glass-fused-to-steel water tank and heat exchanger
- SCAQMD certified Ultra-Low NOx
- Natural gas or propane fuel
- Stealth Quiet™ operation
- Fits through a 36-inch door
- Concentric vent kit available

Turboflue® High Performance Heat Exchanger:

- Patented helical-fin multi-stage design
- Superior heat conduction and fuel efficiency

Made in the USA



BUILT LIKE A BOCK

OT300N2/OT400N2/OT500N2

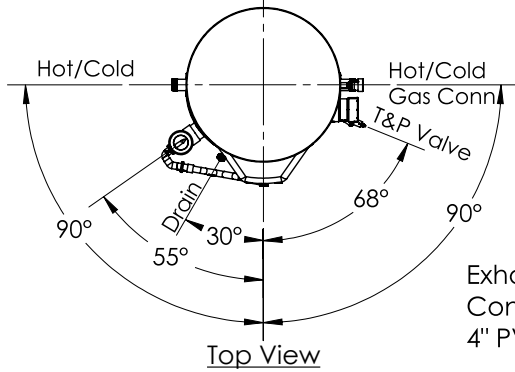

Exhaust Vent Conn./
 Condensate Assembly
 4" PVC

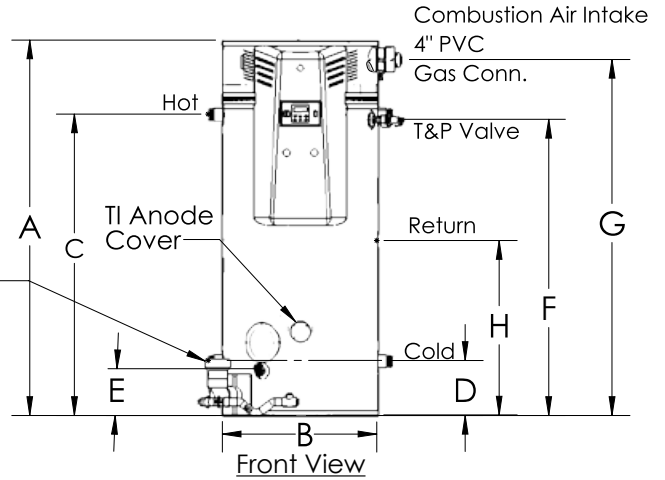

Storage, Inputs, Recovery & Efficiency

Model	Storage GAL (L)	Max. Rated Input BTU/HR (KW)	Min. Rated Input BTU/HR (KW)	Recovery @ 100°F Rise GAL/HR (L/HR)	1st Hr. Del. @ 100°F Rise GAL (L)	Thermal Efficiency @ Max Input (%)	Thermal Efficiency @ Min Input (%)
OT300N2-(A)	119/125 (473)	300,000 (87.9)	80,000 (23.4)	357 (1,351)	480 (1,817)	99	99
OT400N2-(A)	119/125 (473)	399,999 (117.2)	80,000 (23.4)	466 (1,764)	587 (2,222)	97	99
OT500N2-(A)	119/125 (473)	500,000 (146.5)	80,000 (23.4)	576 (2,180)	696 (2,635)	96	99

NOTE: OT 300/400/500 available with 119 gallon Non-ASME version.

Dimensions and Connections

Model	Dimensions in Inches (cm)								Cold NPT	Hot NPT	Recirc. Return NPT	Gas NPT	Air Intake PVC	Exhaust Vent PVC	Shipping Weight LBS (kg)
	A	B	C	D	E	F	G	H							
OT300N2-(A)	78.8 (200)	32.2 (81.8)	62.75 (159)	11.4 (29)	9.4 (24)	61.7 (156)	74.0 (188)	36.3 (9.2)	2"	2"	1"	1.5"	4"	4"	1,100 (500)
OT400N2-(A)	78.8 (200)	32.2 (81.8)	62.75 (159)	11.4 (29)	9.4 (24)	61.7 (156)	74.0 (188)	36.3 (9.2)	2"	2"	1"	1.5"	4"	4"	1,100 (500)
OT500N2-(A)	78.8 (200)	32.2 (81.8)	62.75 (159)	11.4 (29)	9.4 (24)	61.7 (156)	74.0 (188)	36.3 (9.2)	2"	2"	1"	1.5"	4"	4"	1,100 (500)

NOTE: Change the suffix from "N" to "LP" to designate liquid propane.

NOTE: "A" denotes ASME construction.

T&P valve and brass drain valve factory installed.

Standard Voltage (all): 120V, 60 Hz, 1P

Maximum Working Pressure: 150 psi (1034 kPa)

These models meet or exceed current ASHRAE standards.

Warning: Installation should be in accordance with all national and/or local codes. In the absence of local codes, refer to NFPA 54 or CSA B149.1.

Caution: The recommended maximum hot water temperature setting for normal residential use is 120°F. Bock recommends a tempering valve or anti-scald valve be installed and used according to the manufacturer's directions to prevent scalding.





Venting (Materials)

The following materials are approved for use as the vent and combustion air intake piping:

- PVC (DWV, ASTM-D2665 or CSA B181.2)
- PVC (Schedule 40, ASTM-D1785 or CSA B137.3)
- PVC (SDR Series, ASTM-D2241 or CSA B137.3)
- CPVC (Schedule 40, ASTM-F441 or CSA B137.3)
- CPVC (SDR Series, ASTM-F442)
- ABS (Schedule 40, DWV, ASTM-D2661 or CSA B181.1)
- AL29-4C Stainless Steel
- PVC IPEX 1738 (UL 1738, ASTM-D2665)

NOTE: Use of cellular core PVC (ASTM F891), cellular core CPVC, or Radel (polyphenylsulfone) in non-metallic venting systems is prohibited. Covering non-metallic vent pipe and fittings with thermal insulation is prohibited. In Canada, check local codes to ensure that SDR series is approved for use, SDR is not approved for all installations in Canada.

The following materials are approved for use for the fittings in the vent and combustion air intake systems:

- PVS (Schedule 40 DWV, ASTM D2665)
- CPVC (Schedule 40, ASTM F438)
- ABS (Schedule 40, DWV, ASTM D2661)
- AL29-4C Stainless Steel
- PVC IPEX 1738 (UL 1738, ASTM-D2665)

Venting (System Lengths)

Minimum and Maximum Vent Lengths - 4" / 6" Pipe

Model	Pipe Arrangement	Minimum Equivalent Pipe Length (per pipe run)		Maximum Equivalent Pipe Length (per pipe run)	
		Air Intake (ft)	Vent (ft)	Air Intake (ft)	Vent (ft)
OT300N2/ OT400N2/ OT500N2	Power Direct Vent (2 Pipe)	20/50	20/50	50/120	50/120
	Power Vent (1 Pipe)	0/0	20/100	0/0	100/240

Venting (Equivalent Length)

The equivalent straight pipe length of a 90°, 1/4 standard bend elbow and 45°, 1/8 standard bend elbow is 5 feet and 2.5 feet, respectively. **DO NOT** use short bend elbows.

Gas Pressures (OT300-500)

For natural gas:

- MINIMUM GAS SUPPLY PRESSURE (at gas control) = 3.5" W.C. (dynamic)
- MAXIMUM GAS SUPPLY PRESSURE (at gas control) = 10.5" W.C. (dynamic) or 14" W.C. (static)

For LP gas:

- MINIMUM GAS SUPPLY PRESSURE (at gas control) = 8" W.C. (dynamic)
- MAXIMUM GAS SUPPLY PRESSURE (at gas control) = 13"W.C. (dynamic) or 14"W.C. (static)

Note: Dynamic pressure is measured while gas is flowing and static pressure is measured while gas is not flowing.



UL Classified

UL classified in accordance with NSF/ANSI 372 - *Drinking Water System Components (Lead content)* to comply with $\leq 0.25\%$ lead as required by the Reduction of Lead in Drinking Water Act.

UL classified in accordance with NSF/ANSI 5 – *Water Heaters, Hot Water Supply Boilers, and Heat Recovery Equipment*.

Clearances (OT300-500)

Minimum clearances from combustible construction: 0" Sides, 0" Back, 0" Top, 24" Front. 0" from vent connector.

Minimum access clearances for servicing: 12" Left Side, 24" Right Side, 0" Back, 24" Top, 24" Front.

Minimum Clearance From Combustibles

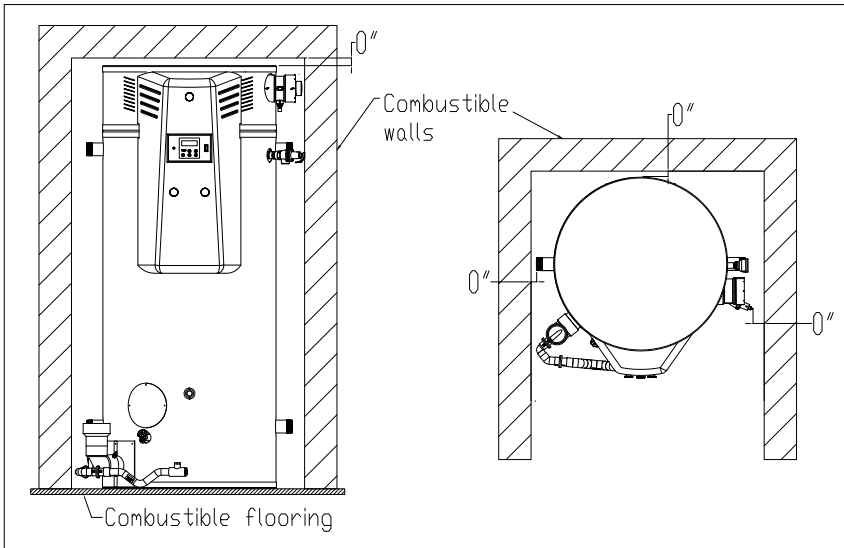

Recommended Minimum Access Clearances

