

**BOCK WATER HEATERS, INC.  
COMMERCIAL ELECTRIC WATER HEATER**

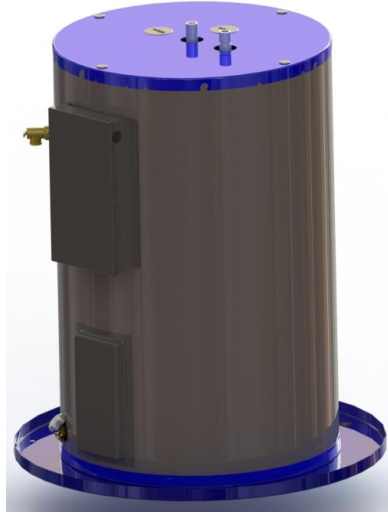

**SUSPENDED PLATFORM  
INSTALLATION MANUAL**

**Models: LCE6-1, LCE12-1, LCE20-1,  
LCE20-2, LCE30-2, LCE40-2**

** WARNING**

**This suspended platform shall be installed by a qualified professional contractor in accordance with the manufacturer's instructions and all applicable codes and requirements of the authority having jurisdiction. The information in these instructions must be followed to minimize the risk property damage, personal injury or death. The qualified service agency is responsible for the proper installation of this platform.**

**Table of Contents**

**General Information**..... 2

**Parts List** ..... 3

**Installation**..... 3

**Warranty**..... 7

## **GENERAL INFORMATION**

Installation of this water heater platform must be performed by a qualified service agency. A qualified service agency is any individual, firm, corporation or company which either in person or through a representative is engaged in and is responsible for the connection, utilization, repair or servicing of structural platforms and equipment; who is experienced in such work, familiar with all precautions required, and has complied with all of the requirements of the authority having jurisdiction.

The 32" diameter model (SP32) is designed to support a 40 gallon, or smaller, Bock nDurance® water heater. The 28" diameter model (SP28) is designed to support a 20 gallon, or smaller, Bock nDurance® water heater.

### **WARNING**

This kit is only for use with Bock nDurance® commercial electric water heaters. Any other use can damage the platform and may result in serious injury or death.

Before installing the suspended platform, verify that the water heater model is compatible with the size of the platform in Table 1.

**Table 1: Platforms and Compatible Water Heaters**

| <b>Suspended Platform Model</b> | <b>Suspended Platform Diameter (inches)</b> | <b>Compatible Water Heater Models</b>               |
|---------------------------------|---|---|
| SP28                            | 28  | LCE6-1, LCE12-1, LCE20-1, LCE20-2                   |
| SP32                            | 32  | LCE6-1, LCE12-1, LCE20-1, LCE20-2, LCE30-2, LCE40-2 |

### **WARNING**

Suspending a water heater model that is not compatible with the specified platform in Table 1 may result in serious injury or death.

## PARTS LIST

### Provided

(1) 32" or 28" Suspended Platform

Supplied by Installer – Both models are compatible with 3/8" or 1/2" hardware.

(4) Threaded steel rod, cut to suitable length

(8) Standard steel nut (hot dipped galvanized or zinc plated)

(8) Standard steel washer (hot dipped galvanized or zinc plated)

(-) Any additional hardware required to secure top of rods to overhead supports

## INSTALLATION

- 1) Install platform mounting hardware and threaded rod to overhead structure using the layouts in Figure 1 or by holding the pan to the mounting surface and marking the location of each hole. The mounting installation for each rod must be capable of supporting a minimum of 600 pounds (2400 pounds total). The mounting installation includes all hardware used to attach each rod to the overhead structure.

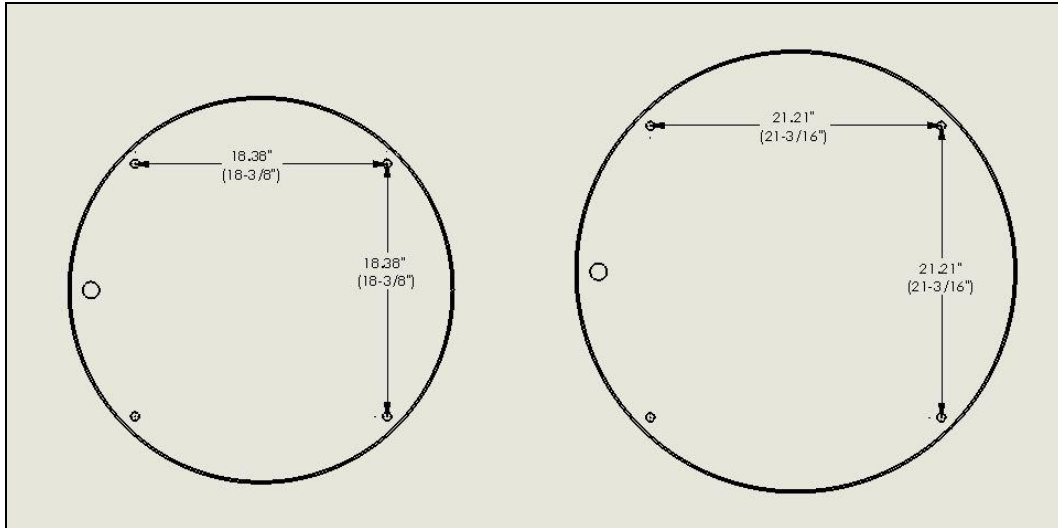
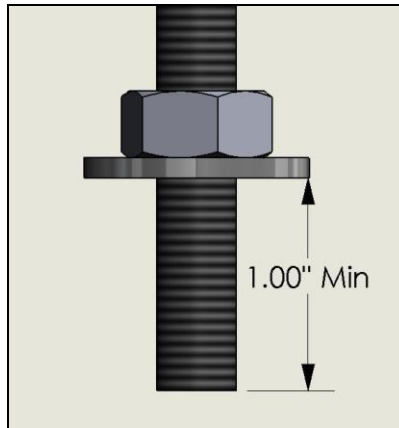

Figure 1: Mounting hardware layout

### **! WARNING**

Failure to ensure that the structure and hardware used for installation of this platform are sound can result in property damage, serious injury or death.

- 2) Install one nut on the bottom of each threaded rod. Ensure that a minimum of 1" of threaded rod extends below the nut when washer is installed.



**Figure 2:** Top nut installation

- 3) Place empty nDurance® water heater on platform, ensuring that the heater is centered on the platform and that the junction cabinet can be accessed once mounting rods are installed.

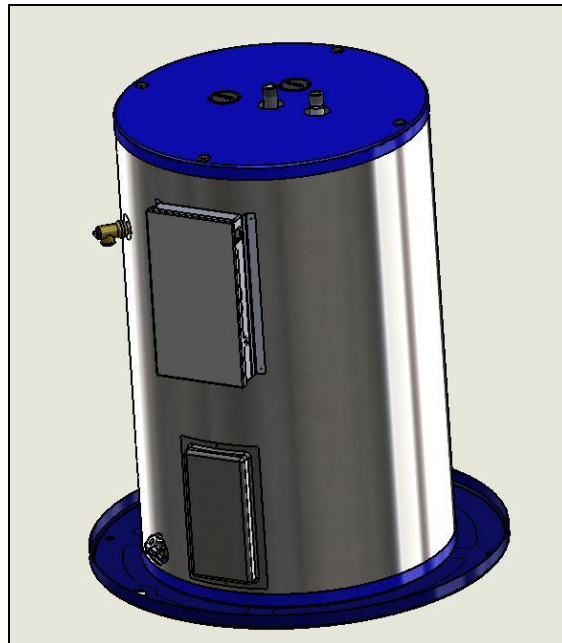

**Figure 3:** Water heater placement on platform

- 4) Lift platform and water heater to threaded rod. Install threaded rod ensuring that a washer is located between the nut and the top of the platform.

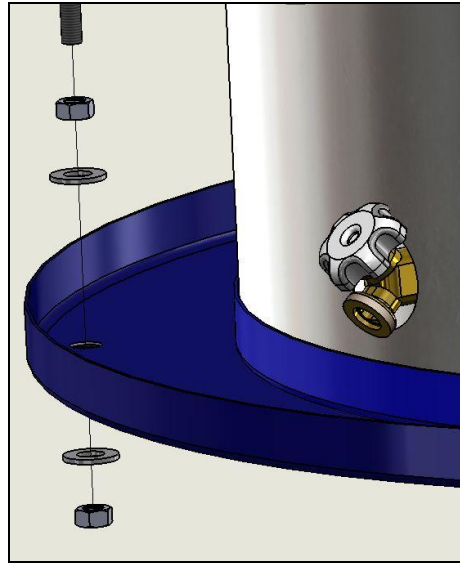

Figure 4: Hardware order of installation

- 5) Install washer and nut on threaded rod underneath the platform so that  $\frac{1}{4}$ " of thread is exposed underneath the nut.

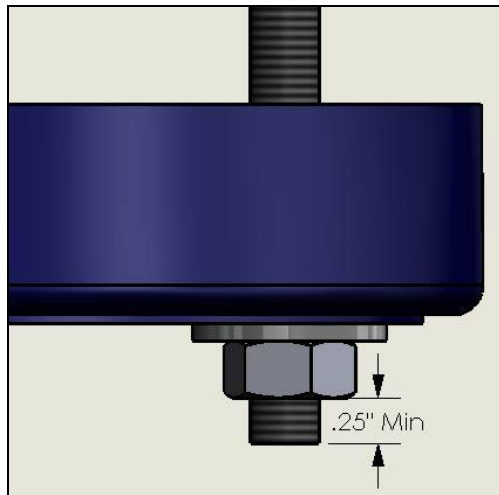

Figure 5: Threaded rod stick-out

- 6) Repeat steps 4-5 for remaining rods.

- 7) Once the platform is secured to the structure, check to ensure the water heater is level by placing a level directly between two rods on the bottom of the platform as shown in Figure 6. Tighten the bottom nuts as needed to level the platform. Turn the level 90 degrees so that it is facing the other two rods and tighten bottom nuts as needed.  
*(Note: Top nuts may be loosened if they interfere with tightening the bottom nuts while leveling the water heater.)*

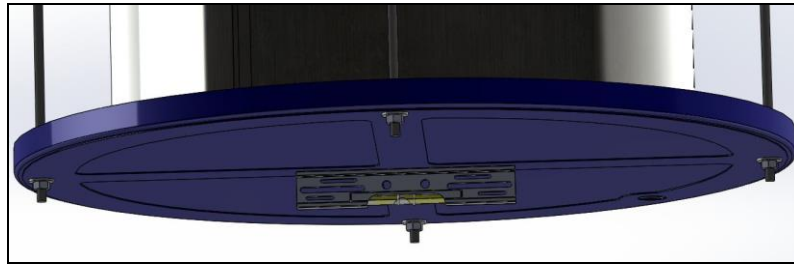

Figure 6: Correct level placement

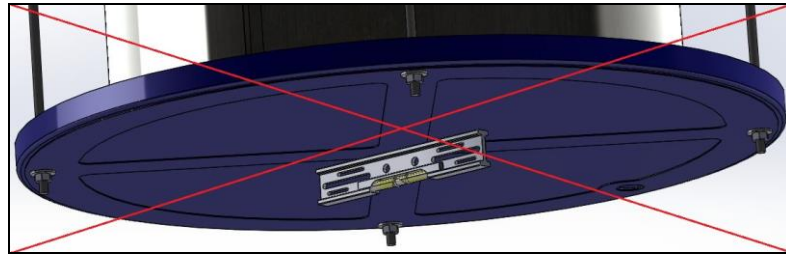

Figure 7: Incorrect level placement

- 8) With the water heater leveled, hand-tighten the top nuts. Add  $\frac{1}{2}$  turn past hand tight.
- 9) A  $\frac{3}{4}$ " drain spud is located on the bottom of the suspended platform. An adapter will be needed for drain installations using anything other than  $\frac{3}{4}$ " NPT pipe. Do not cover the drain spud with the water heater.

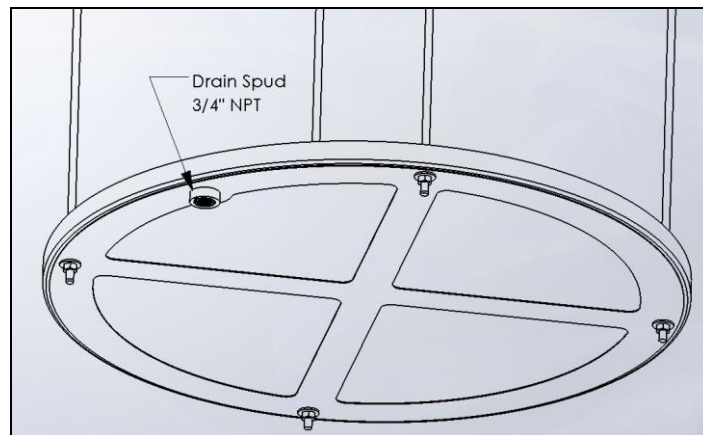

Figure 8: Drain spud location

## ***LIMITED WARRANTY FOR SUSPENDED PLATFORM***

### **WHAT DOES THIS LIMITED WARRANTY COVER?**

This limited warranty applies only to the original purchaser.

This warranty covers defects in workmanship or materials in the suspended platform for a period of one year from the original installation date. The suspended platform is defined as only the sheet metal platform that serves as the supporting base under the water heater. It does not include threaded rods, nuts, washers, or any hardware used to anchor to a supporting structure.

The qualified service agency that installs the platform is responsible for defects in workmanship or materials for all other parts utilized for installation.

### **HOW DO YOU GET SERVICE UNDER THE LIMITED WARRANTY?**

In order for the warranty period to begin on the date of installation, you must return the warranty registration card attached below within 30 days of purchasing the suspended platform. You may also register your suspended platform online at [www.bockwaterheaters.com](http://www.bockwaterheaters.com). You must have a copy of the original sales receipt at the time you request service. Failure to return the warranty registration card and provide a copy of the sales receipt will result in the warranty period beginning from the date of manufacture.

To get service under this limited warranty you should contact either the dealer or installer. If dealer or installer is unknown you can contact us via email at [warranty@bockwaterheaters.com](mailto:warranty@bockwaterheaters.com) or call us Monday through Friday between the hours of 8:00 AM to 5:00 PM Central Time at 1-608-257-2225.

You can also write us at the following address:

Bock Water Heaters, Inc.  
110 S. Dickinson St.  
Madison, WI 53703

We will respond no later than ten days after we receive your request for service.



## **WHAT DOES THIS LIMITED WARRANTY NOT COVER?**

This limited warranty does not cover suspended platforms that are or were:

- Incorrectly installed, especially where the installation violates state or local plumbing, housing, or building codes.
- Installed with water heater models not listed in Table 1 (see page 2) of this manual.
- Installed to support a static load that exceeds the weight of the largest water heater (filled with water) that is approved for a given suspended platform in Table 1 (see page 2) of this manual.
- Suspended platform failure due to a seismic event.
- Accidental damage to the platform prior to installation.

Also, we will not cover the following charges, costs and losses:

- Any freight or delivery charges.
- Any removal or installation charges.
- Charges to return the suspended platform to the manufacturer.
- Water damage, loss or damage to property, inconvenience or loss of use.

## **WHAT WILL VOID THE LIMITED WARRANTY?**

If you do any of the following, you will void this limited warranty:

- Fail to return the warranty registration card within 30 days.
- Fail to retain the original copy of your sales receipt.
- Transfer or sell the suspended platform.
- Remove the suspended platform from its original location and install it somewhere else.
- Failure to follow the installation instructions provided with the suspended platform.

## **HOW DOES STATE LAW RELATE TO THIS LIMITED WARRANTY?**

This is a limited warranty. WE MAKE NO OTHER EXPRESS WARRANTIES WITH RESPECT TO THIS SUSPENDED PLATFORM. We will not assume, nor authorize any person to assume for us any other liability in connection with the sale or operation of this suspended platform. ANY IMPLIED WARRANTIES, INCLUDING MECHANTABILITY OR FITNESS FOR A PARTICULAR APPLICATION, IMPOSED ON THIS SALE UNDER THE LAWS OF THE STATE OF SALE ARE LIMITED TO ONE YEAR. This warranty gives you specific legal rights, and you may also have other rights which vary from state to state. Some states

do not allow limitations on how long an implied warranty lasts, so the above limitation may not apply to you.

WE WILL NOT BE RESPONSIBLE FOR WATER DAMAGE, LOSS OF USE OF THE UNIT, INCONVENIENCE, LOSS OR DAMAGE TO PERSONAL PROPERTY, WHETHER DIRECT OR INDIRECT, AND WHETHER ARISING IN CONTACT OR TORT. Some states do not allow the exclusion of incidental or consequential damages, so the above exclusion may not apply to you.

*Cut here* → .....

**LIMITED WARRANTY REGISTRATION CARD**

Return this portion within 30 days of date of installation to:

BOCK WATER HEATERS  
P.O. BOX 8632  
Madison, WI 53708-8632

Name \_\_\_\_\_

Street Address \_\_\_\_\_

City/State/Zip \_\_\_\_\_

Suspended Platform Model (SP28 or SP32) \_\_\_\_\_

Serial Number of Water Heater on Platform \_\_\_\_\_

Date of Installation \_\_\_\_\_

Installed By \_\_\_\_\_

*Cut here* → .....

**Bock Water Heaters, Inc. • 110 South Dickinson Street • Madison, WI 53703**  
**Telephone 608-257-2225 • Fax 608-257-5304**  
**[www.bockwaterheaters.com](http://www.bockwaterheaters.com)**