GENERAL SIZING FORMULA

All requirements for hot water should be totaled to obtain the maximum amount of hot water required per hour. Use multiple water heaters when the requirements exceed the capacity of a single heater. If too many heaters in multiples will be required, use a storage tank sized to the gallons of hot water required per peak hour and heat the water in the tank with heaters having a recovery of one-third the capacity of the storage tank. Except in the case of self-service laundries, this total use could be factored by judgement – assuming that not all fixtures will be on at the same time – 75% to 80%, for example.

Sizing Formula for BTUH Input

Desired temperature..... 140°F
Inlet water temperature 50°F
1. Temperature difference..... 90°F
2. Expected flow rate 5 GPM x 60 minutes = 300 GPH
3. BTU/gallon °F (water) 8.25

Total expected BTUH output is:

90°F x 300 gallons x 8.25 BTUs = 222,750 BTUH

To find the input required to produce 222,750 BTUH output, divide by .80

$$\frac{222,750}{.80} = 278,438 \text{ BTUH input}$$

* The Bock recommended Recovery / Efficiency

INDIRECT WATER HEATER APPLICATIONS

The Bock indirect water heaters are designed as a long life water heater for use in domestic and light commercial applications in buildings using boilers for space heating. The concept behind using an indirect is that the boiler heats water when it is not heating the home. This causes the boiler to run more frequently, reducing the boiler stand-by times and associate losses. Installing a dedicated boiler to power an indirect water heater is not an efficient way to heat water.

When selecting an indirect water heater, choose a tank size that can easily meet the immediate hot water demands of the customer. Do not count on recovery to help meet the load of a single draw. The reason for this is that the typical boiler will take two

or more minutes to get to operating temperature before it can begin to heat the water in the tank. This means that most or all hot water stored in the tank could be gone by the time the boiler can begin to recover the tank.

Example:

The customer uses 40 gallons to fill a bathtub. What size indirect should be used? The minimum tank size for this application would be a 50SK. A 40SK will deliver 33 gallons of usable hot water in a single draw and would not be able to fill the tub, resulting in customer complaints.

MULTIPLE DWELLING BUILDINGS

Tables 11A, 11B and 11C are based on ASHRAE Chapter 32: "Service Water Heater Tables," use 3 GPM shower heads and figure two to 2.5 people per unit. These tables may not be applicable to FHA sizing for some apartment building categories due to different diversity factors than those applied in the ASHRAE Guide.

If larger shower heads or extra-heavy use is predicted, sizing should be based on Table 11.

TABLE 11

Apartments, Hotels & Motels

INPUT BTUH	APARTMENTS			MOTELS/ HOTELS	GAS	OIL/PG	ELECTRIC	INDIRECTS
	LIGHT	AVG	HEAVY					
95,000	3	2	1	3	1-EZ75-135	1-32E/PG	1-27KW	1-80SK
110,000	4	3	2	4	1-EZ75-135	1-51E/PG	1-36KW	1-80SK
140,000	5	4	3	5	1-EZ75-135	1-51E/PG	1-40KW	1-119SK
175,000	6	5	4	6	1-EZ80-156	1-71E/PG	1-54KW	1-119SK
200,000	8	7	6	8	1-EZ80-199	1-72E/PG	2-30KW	2-50SK
230,000	12	10	9	12	1-EZ100-199	1-73E/PG	2-36KW	2-50SK
280,000	20	17	14	20	2-EZ75-135	1-241E/PG	2-45KW	2-80SK
360,000	31	2	18	31	2-EZ80-156	2-71E/PG	3-36KW	2-119SK
460,000	37	28	22	37	2-EZ100-199	1-361E/PG	3-45KW	N/R
500,000	52	40	32	52	3-EZ80-156	2-241E/PG	3-54KW	N/R
600,000	72	55	44	72	3-EZ80-156	1-541E/PG	4-45KW	N/R
1,500,000	221	166	132	221	1-150/250G	1-150/ 250E/PG	N/R	N/R

N/R = Not Recommended

LIGHT LOAD: Two people per unit; 3 GPM shower or less. Central laundry facilities (for individual laundries add 10% more input).

AVERAGE LOAD: Three to five people per unit; 4 to 6 GPM shower. Central laundry facilities (for individual laundries add 10% more input).

HEAVY LOAD: More than six people per unit; two baths. Individual laundry facilities.

Chart assumes recirculating line. If none, add 20% to required input.

All sizing based on 100°F rise in water temperature.

Hot water for food service units in motels/hotels should be sized separately.

For 90°F temperature rise, decrease required input by 10%. For 80°F temperature rise, decrease required input by 20%.

Federal regulations require all shower heads to be a maximum of 2.5 GPM. In older homes and buildings, larger GPM shower heads may be found and should be factored into sizing (see Table 15).

Note: U.S. Department of Housing and Urban Development Minimum Property Standards; 4910.1 - 1973, paragraph 615-5 states: "Hot water requirements for multiple dwellings should be based on design criteria shown in the ASHRAE Guide."

TABLE 11A

Apartment Sizing, 4 to 25 units

	TYPE OF FUEL	50°F	70°F	90°F	100°F
		RISE	RISE	RISE	RISE*
		MODEL	MODEL	MODEL	MODEL
4 UNITS	OIL P/GAS GAS ELEC. INDIRECT	32E 32PG EZ75-135 50F-15 50SK	32E 32PG EZ75-135 50F-15 50SK	32E 32PG EZ75-135 50F-15 50SK	51E 51PG EZ75-135 80F2C-15 80SK
6 UNITS	OIL P/GAS GAS ELEC INDIRECT	32E 32PG EZ75- 13550F-18 50SK	51E 51PG EZ75-135 50F-18 50SK	51E 51PG EZ75-135 50F-18 80SK	71E 71PG EZ75-135 80F-18 80SK
8 UNITS	OIL P/GAS GAS ELEC INDIRECT	51E 51PG EZ75-135 80F-15 80SK	51E 51PG EZ75-135 80F-15 80SK	51E 51PG EZ75-135 80F-15 80SK	71E 71PG EZ75-135 80F-18 80SK
10 UNITS	OIL P/GAS GAS ELEC INDIRECT	51E 51PG EZ75-135 80F-18 80SK	51E 71PG EZ75-135 80F-24 119SK	51E 71PG EZ75-135 N/R 119SK	72E 72PG EZ75-135 80F-30 119SK
12 UNITS	OIL P/GAS GAS ELEC INDIRECT	51E 51PG EZ75-135 80F-24	51E 71PG EZ75-135 120F-27 80F-30 119SK	51E 71PG EZ75-135 120F-27 119SK	241E 241PG EZ100-199 120F-30
15 UNITS	OIL P/GAS GAS ELEC INDIRECT	51E 51PG EZ75-135 80F-30 119SK	51E 71PG EZ75-135 80F-30 119SK	71E 71PG EZ80-156 120F-30 119SK	241E 241PG EZ100-199 120F-36 80SK(2)
20 UNITS	OIL P/GAS GAS ELEC INDIRECT	71E 71PG EZ75-135 120F-30 119SK	71E 71PG EZ75-135 80F-36 119SK	72E 72PG EZ80-156 80F-45 80SK(2)	241E 241PG EZ100-199 120F-45 80SK(2)
25 UNITS	OIL P/GAS GAS ELEC INDIRECT	72E 72PG EZ80-156 120F-36 80SK(2)	73E 73PG EZ100-199 120F-45 119SK(2)	241E 241PG N/R 120F-45 119SK(2)	N/R N/R N/R N/R N/R

N/R = Not Recommended

* **Note:** Indirects are not recommended for use at outlet temperatures of more than 140°F.

TABLE 11B

Apartment Sizing, 30 to 72 units

	TYPE OF FUEL	50°F RISE MODEL	70°F RISE MODEL	90°F RISE MODEL
30 UNITS	OIL	72E (2) 51E	241E (2) 71E	361E (2) 71E
	P/GAS	72PG (2) 51PG	241PG (2) 71PG	361PG (2) 71PG
	GAS	EZ80-156 (2) EZ75-135	— (2) EZ75-135	— (2) EZ80-156
	ELEC.	120C-45 (2) 52C-24	120C-54 (2) 82C-27	(2) 82C-30 —
36 UNITS	OIL	72E (2) 32PP	241E (2) 51E	361E (2) 71E
	P/GAS	72PG (2) 32PG	241PG (2) 51PG	361PG (2) 72PG
	GAS	EZ80-156	(2) EZ75-135 —	(2) EZ80-156 —
	ELEC.	82C-45 (2) 52C-24	120C-54 + 90-Gal. (2) 82C-30	(2) 82C-36 —
48 UNITS	OIL	241E (2) 51E	361E (2) 71E	(2) 73E
	P/GAS	241PG (2) 51PG	241PG (2) 71PG	(2) 73PG —
	GAS	(2) EZ80-156	(2) EZ100-199	—
	ELEC.	(2) 82C-30 —	120C-54 + 90-Gal. (2) 82C-36	(2) 120C-45
60 UNITS	OIL	361E (2) 51E	(2) 73E	200E-600 541E (2) 241E
	P/GAS	361PG (2) 71PG	(2) 73PG	541PG
	GAS	(2) EZ80-156	—	—
	ELEC.	(2) 120C-30	(2) 82C-45	(2) 120C-54
72 UNITS	OIL	361E (2) 72E	(2) 241E	250E-800 (2) 361E
	P/GAS	361PG 72PG	541PG (2) 241PG	(2) 361PG
	GAS	(2) EZ80-156	—	150G-800
	ELEC.	52C-36	(2) 82C-54	(3) 120C-36

TABLE 11C

Apartment Sizing, 100 to 150 units

	TYPE OF FUEL	50°F RISE MODEL	70°F RISE MODEL	90°F RISE MODEL
100 UNITS	OIL	150E-800 (2) 241E (3) 71E	250E-800 (2) 361E (3) 73E	250E-1000 (2) 541E (3) 361E
	P/GAS	(3) 241PG (2) 361PG	(3) 361PG (3) 73PG	(2) 361PG —
	GAS	— (3) EZ80-156	— 150G-800	— 150G-800
	ELEC.	(2) 82C-45 (3) 52C-27 (4) 82C-30	(2) 82C-54 (3) 52C-36 (4) 82C-36	(3) 120C-36
150 UNITS	OIL	250E-800 (2) 361E (3) 241E (4) 72E	250E-1000 (3) 361E (4) 241E	250E-1250 (3) 541E (4) 361E
	P/GAS	(2) 361PG (3) 241PG (4) 72PG	(2) 541PG (3) 361PG (4) 241PG	(3) 541PG (4) 361PG
	GAS	250G-800 (4) EZ80-156	250G-1000	250G-1500
	ELEC.	(3) 82C-45 (4) 52C-30	(3) 82C-54 (4) 82C-45	(6) 82C-54

EXPANSION TANK SIZING

The cold water supply to the water heater may contain a check valve, pressure reducing valve and/or a back flow preventer, creating a “closed system.” As the heated water expands, it creates a pressure buildup in the closed system. This may cause the T&P (temperature and pressure) relief valve to weep and/or discharge water. To prevent this, an expansion tank must be installed in the cold water supply line.

Size the expansion tank to 10% of the water heater’s capacity.

Example: Heater capacity = 30 gallons / 10% requires a minimum three-gallon tank.

Note: For commercial and farm applications, consideration should be given to piping size and capacity.

Always check with the manufacturer of the expansion tank for sizing.

HAIR SALONS

The size of water heating equipment for a hair salon is based on the number of basins used. Because most hot water is used for washing hair, assume each station or chair uses 12 gallons of hot water per hour based on each shampoo lasting five to six minutes with a maximum of four shampoos per hour per basin. If in doubt, refer to Table 12 below.

TABLE 12

Hair Salon Sizing

CHAIRS	GAS	OIL & PG	ELECTRIC
1-6	1 - EZ75-135	1 - 51E/PG	1 - 15KW
7-8	1 - EZ75-135	1 - 71E/PG	1 - 40KW
9-14	1 - EZ100-199	1 - 72E/PG	2 - 30KW
15-27	2 - EZ75-135	1 - 361E/PG	2 - 54KW
28-35	2 - EZ100-199	1 - 541E/PG	3 - 54KW
36-49	3 - EZ100-199	2 - 361E/PG	4 - 54KW
50-70	4 - EZ100-199	2 - 541E/PG	6 - 54KW

Heater size is based on the number of stations/chairs, with incoming water at 40°F and delivered temperature at 140°F.

Sizing is based on a 100°F rise in water temperature. For a lower rise, multiply the number of stations/chairs by the appropriate factor before determining the water heater requirement.

Example: For a 90°F rise in water temperature, multiply the number of stations by .90. For an 80°F rise, multiply the number of stations by .80.

Washing machines for laundry should be sized according to the self-service laundry section on page 25.

Important:

Corrosive products such as hair spray must be kept away from water heating equipment. When mixed with combustion products, such products can become very aggressive and may actually corrode the heater from the outside in.

Make sure that ample fresh outside air is supplied to the heater and that the boiler room door is always closed off from aromatic sprays.

BARBER SHOPS

Although less hot water is used to wash men's hair than women's, more high temperature water is used for hot towel applications during a shave. Use the same calculations and table as for hair salons.

CAR WASHES

Most car washes use 110°F water to protect auto finishes, although slightly hotter water may be used to clean tires. A storage tank is recommended and should be set to the highest temperature required for the system. If wheels and tires are washed with water power, storage temperatures can range from 160°F to 180°F and mixed with cold water.

Caution: In cold climates, higher temperature water delivered under pressure will vaporize and turn to steam before reaching the vehicle. In northern climate winter, ice removal can be accelerated by pre-rinsing the vehicle with 120°F water.

Important:

The water heater must be supplied with fresh, outside air and the boiler room door must be kept closed to protect the heater from detergent fumes and aromatic car "freshener" fumes. When mixed with combustion products these fumes will inhibit good combustion and can corrode a heater from the outside in.

PLACES OF WORSHIP

Hot water requirements for places of worship will be determined by the largest use, usually food preparation and/or dish washing. If the building is equipped with a machine dishwasher, the hot water requirement will be found in Table 17, pages 25 - 27. If the building does not have a machine dishwasher, base the requirement on two gallons of hot water per person per meal served.

Example: The building has five showers, each rated at 4 GPH flow, 10-minute use; six sinks; and a 2-E Blakeslee dishwasher.

General Purpose Water:

Showers: 5 x 4 x 10 =200 gallons
 Sinks: 6 x 5 =30 gallons
 TOTAL REQUIREMENT230 gallons
 (may be accomplished using storage)

Food Service (from Table 17,

2-E Blakeslee dishwasher, 140°F general purpose; 180°F rinse water, 288 gallons (pre-rinse: 180 gallons)

Food service (the largest requirement) will also be adequate for shower and sink use, as use normally occurs at other times.

Use two Bock Model EZ100-199 as preheaters and a Model EZ75-135 as a 180°F booster, **or** two Model 241E or 241PG with a 71E or 71PG as a booster.

Without a machine dishwasher, the requirements are:

Showers, 5 x 4 x 10 = 200 gallons

Sinks, 6 x 5 = 30 gallons

Food service, 250 x 1/2 = 125 gallons
(1/2 gallon per person per meal)

Showers (the largest requirement) will also be adequate for food service use, as use normally occurs at other times.

Use one Bock Model 75W-300SD, one 361E, one 361PG or one 118C-54 electric.

The application for a baptistry tank is similar to a swimming pool except the warm-up period is shorter, there is no filter or pump and the tank is drained between baptismal services. The desired temperature is usually 80°F to 100°F but may vary. Refer to the Swimming Pool section of this manual on page ___ for sizing information.

SCHOOLS

Because water heating requirements may use between 5% and 15% of the total energy consumed in a school, proper sizing with efficient systems is very important. Normally, efficient systems follow these principles:

1. Schools may have several hot water requirements such as the gymnasium, cafeteria, clean-up and general purpose use. Separate water systems should be used for each application, with the system located as closely as possible to the end use to avoid long pipe runs of hot water lines.
2. Insulate all hot water lines and storage vessels.
3. The thermostat settings should be lowered to 120°F on water heaters used for general purposes and clean-up.
4. Use booster heaters for cafeteria applications requiring 180°F water for machine dishwashers, but heat only the water used for the sanitizing rinse.

Method of Sizing

There are two methods of sizing the hot water requirements of schools. The first is more exacting and will provide a more energy-efficient system by using a separate system for each requirement. The second is if a single system is used for all requirements and there are not extraordinary hot water demands such as after-school athletic use.

Sizing by individual hot water requirements is recommended, rather than sizing by the number of students. It classifies hot water requirements into three categories:

1. General purpose use
2. Cafeteria use
Use the food service section of this manual for school cafeteria sizing.
3. Gymnasium shower use
 - A. Schools with showers used only for gym class have relatively stable hot water requirements and are used about 10 minutes per hour with a 50-minute recovery time between shower intervals. Sink hot water requirements are typically low. Size these applications by the number of shower heads to be serviced and their flow rates.
 - B. Schools with moderate after-school use, such as basketball practice and wrestling require longer shower periods. Size for 20 minutes of continuous shower flow.
 - C. Schools with heavy after-school use, such as football practice and larger athletic events should be sized for a 30-minute shower period and long recovery time. A water heating system with a large external storage tank can be used.

Gymnasium Unit Method Sizing

To determine the sizing for school gymnasium use, use the following factors:

1. Number of shower heads.
2. Flow rate of the shower heads. New facilities will have shower heads at 2 1/2 GPM; older buildings may have much larger shower heads.
3. Temperature rise – the required temperature of hot water less the temperature of incoming cold water.
4. Type of use: light, moderate or heavy.

Example:

20 shower heads, 3 GPM flow rate, 20-minute usage per shower head.

$20 \times 3 \times 20 = 1,200$ gallons per 20-minute shower requirement

Five sinks: 5 GPM usage.

$5 \times 5 = 25$ GPH sink requirement

Bradley Washfountain: One 36-inch full-size 4 GPM flow rate, 10 minute usage per hour.

$4 \times 10 = 40$ gallons per 10-minute washfountain requirement

TOTAL REQUIREMENTS:

$1,200 + 25 + 40 = 1,265$ gallons per 20-minute demand period

For this requirement, use one Bock Model 250-800 heater with a 1,000-gallon storage tank. A single 250 will provide 527 gallons of hot water in 20 minutes at 90°F rise. The additional 738 gallons are obtained from the 75% usable storage in the 1,000-gallon storage tank.

Caution: For peak demands beyond normal use go to larger storage.

For schools with swimming pools see the Swimming Pool sizing section of this manual, page 27.

INDUSTRIAL PLANTS

In small industrial plants all hot water needs can be supplied from a central installation.

For better economy and service in larger plants, hot water should be provided from individual installations at each use location.

To determine industrial hot water requirements, group the outlets first. If a central location is advisable, the hot water load for all uses should be totaled and equipment sized accordingly.

If individual locations at points of use is more advisable, size each area's requirements separately.

General purpose hot water for showers and Bradley Washfountains should be based on 100% flow for 10 minutes (see Table 13, page 21).

Hot water for sinks and slop sinks is based on gallons per hour (see Table 12, page 18).

For special applications such as washing, cleaning or product processing, rate of flow times length of use should be determined to give the total requirement. Using this total, Tables 33 - 50, pages 58 - 75 can be used to size the water heater(s).

Example, Small Plant

A small industrial plant has one 54-inch Bradley Wash-fountain, four sinks and one slop sink.

Washfountain: 7 GPM flow rate for 10 minutes usage.
 $7 \times 10 = 70$ gallons

Sink: 5 GPH usage.

$$4 \times 5 = 20 \text{ gallons}$$

Slop sink: 20 GPH usage.

$$1 \times 20 = 20 \text{ gallons}$$

TOTAL USAGE:

$$70 + 20 + 20 = 110 \text{ gallons for 10-minute demand}$$

For this requirement use one Bock Model 241E or 241PG. Refer to Tables 33 - 50, pages 58 - 75.

Example, Large Plant

A large industrial plant has two 54-inch Bradley Wash-fountains and eight shower heads.

Shower heads: eight, each with 2.5 GPM flow rate, 10-minute usage.

$$8 \times 2.5 \times 10 = 200 \text{ gallons per 10-minute usage}$$

Bradley Washfountains: Two 54-inch washfountains, 7 GPM flow rate, 10-minute usage each.

$$2 \times 7 \times 10 = 140 \text{ gallons per 10-minute usage.}$$

TOTAL USAGE:

$$200 + 140 = 340 \text{ gallons in 10 minutes.}$$

Use two 541PG or 541E water heaters manifolded.

DAIRY BARN

Most dairy barn applications require 180°F water for sterilizing procedures. A large volume of water may be required in a short time span so a storage tank should be used. Where a Bock is replacing an existing electric water heater, if the tank is in good condition it can be used for storage.

Note: The standard operating controls on models 51E/PG and 71E/PG are not designed for this application and must be ordered from the factory equipped to provide 180°F water. Bock 30- and 40-gallon units cannot be used in this application.

CARE CENTERS, DORMS, OFFICE BUILDINGS, CLUBS

When referring to relevant tables, remember that there are additional considerations in determining the hot water needs for each of the following installations:

Assisted Living Facilities

Water heater sizing in this section addresses the hot water necessary for baths, showers, sinks, laundry, general cleaning and kitchen use. 180°F water for machine dish-washing should be provided by a separate booster heater. The ASHRAE Guide indicates the need for 4.5 gallons of hot water per bed per maximum hour and 30 gallons per bed per day. Use caution in determining requirements.

Bock highly recommends the installation of anti-scald or mixing valves to maintain 120°F water – water temperatures in excess of 120°F can cause scalding, serious injury or death.

Office Buildings

Sizing is based on hot water requirements for cleaning and lavatory use of occupants and visitors. Food service should be sized separately according to the Food Service section of this manual on page 23. Reasonable fuel economy can be achieved through the use of a time clock (a Paragon or the equivalent) that shuts off the water heater on weekends.

Dormitories

Food service is not included in dormitory sizing and must be considered separately. The hot water consumption at a dorm is based on a one-hour peak demand.

Country Clubs and Health Clubs

Country club use is similar to school gymnasiums, except that such clubs have their heaviest demand during weekends and summer months. To size for clubs, refer to the school gymnasium format, page 19.

Restaurants at clubs should be sized using Tables 16 and 17. Size for swimming pools using the Swimming Pool guide on page 27.

TABLE 13

Sizing for Dormitories

100% RECOVERY AND NO EXTRA STORAGE AT 70°F

NO. OF MEN	NO. OF WOMEN	PEAK LOADS	OIL MODEL	POWER GAS MODEL	ATMO. GAS MODEL	ELECT. MODEL
15	10	50 GPH	32E	32PG	EZ75-135	82C-15
	15	75 GPH	32E	32PG	EZ75-135	82C-18
25	20	100 GPH	32E	32PG	EZ75-135	82C-24
30	25	125 GPH	32E	32PG	EZ75-135	82C-36
40	30	150 GPH	51E	51PG	EZ75-135	82C-36
	30	160 GPH	51E	51PG	EZ75-135	82C-45

Table 13 continued in next column ...

TABLE 14

Hot Water Requirements for Fixtures and Machines

TYPE OF FIXTURE OR MACHINE	FLOW RATE	DEMAND	TEMPERATURE
BATHTUB	4 GPM	20 GPH	120°F to 110°F
SINK	3 GPM	5 GPH	120°F to 110°F
CIRCULAR WASH FOUNTAIN, 54" DIAMETER	7 GPM	70 GPH	120°F to 110°F
SEMICIRCULAR WASH FOUNTAIN, 54" DIAMETER	3.5 GPM	35 GPH	120°F to 110°F
5-IN-A-GROUP SHOWER	12.5 GPM	125 GPH	120°F to 110°F
3-IN-A-GROUP SHOWER	7.5 GPM	75 GPH	120°F to 110°F
CORNER SHOWER	5 GPM	50 GPH	120°F to 110°F
CIRCULAR COLUMN SHOWER	12.5 GPM	125 GPH	120°F to 110°F
SEMI-CIRCULAR COLUMN SHOWER	7.5 GPM	75 GPH	120°F to 110°F
HAIR SALON FIXTURE/STATION	3 GPM	12 GPH	120°F to 110°F
BARBER SHOP LAVATORY	3 GPM	5 GPH	120°F to 110°F
RESTAURANT AUTOMATIC DISHWASHER	4 GPM	7 GPH	140°F
MOP SINK	3 GPM	15 GPH	140°F
BAR SINK	3 GPM	25 GPH	140°F
SINGLE POT SINK	4 GPM	25 GPH	140°F
DOUBLE POT SINK	4 GPM	50 GPH	140°F
TRIPLE POT SINK	4 GPM	75 GPH	140°F
VEGETABLE SINK	4 GPM	40 GPH	140°F
HANDSPRAY DISH PRE-RINSE	4 GPM	45 GPH	140°F
BRUSH-TYPE DISH PRE-RINSE	3 GPM	180 GPH	140°F
CONVEYOR DISH PRE-RINSE *	4 GPM	240 GPH	140°F
AUTOMATIC 9 LB. TO 12 LB. CLOTHES WASHER	5 GPM	36 GPH	160°F
STATIONARY RACK DISHWASHING MACHINE	SEE FOOD SERVICE SECTION		140°F TO 180°F
CONVEYOR DISHWASHING MACHINE	SEE FOOD SERVICE SECTION		140°F TO 180°F

* May be built into dishwasher; frequently used as separate appliance

CAUTION: 180°F water generated by the heating system should be connected only to the rinse inlet of the dishwasher and possibly to the wash tank fill. The pre-wash or scrapping section of the dishwashing operation and the general purpose sinks throughout the kitchen should not receive any water hotter than 140°F unless local health regulations require one pot sink to be serviced by 180°F water. If so, the faucet should be clearly marked.

WARNING! 180°F water can cause scalding, serious burns and death!

... **TABLE 13** continued

Sizing for Dormitories

100% RECOVERY AND NO EXTRA STORAGE AT 70°F

NO. OF MEN	NO. OF WOMEN	PEAK LOADS	OIL MODEL	POWER GAS MODEL	ATMO. GAS MODEL	ELECT. MODEL
40	35	175 GPH	51E	51PG	EZ75-135	82C-45
45	35	180 GPH	51E	51PG	EZ75-135	82C-45
50	40	200 GPH	51E	51PG	EZ75-135	82C-45
55	45	225 GPH	71E	71PG	80W-180SD	82C-54
	50	250 GPH	72E	72PG	80W-180SD	82C-54
65	55	275 GPH	72E	72PG	EZ80-156	---
	60	300 GPH	72E	72PG	EZ100-199	---
80	65	325 GPH	241E	241PG	80W-250SD	---
	70	350 GPH	241E	241PG	100W-250SD	---
94	75	375 GPH	241E	241PG	75W-300SD	---
100	80	400 GPH	241E	241PG	75W-300SD	---
	85	425 GPH	241E	241PG	75W-300SD	---
112	90	450 GPH	361E	361PG	75W-300SD or 66W-370SD	---
125	100	500 GPH	361E	361PG	80W-399SD	---

TABLE 15

Shower Head by Manufacturer's Model

NOTE: Federal law limits all new shower heads to 2.5 gallons per minute

MANUFACTURER	MODEL	GPM (105°F) NORMAL FLOW
ALSONS	44PB	2.0
	110DPB	2.0
	605	2.75
AMERICAN STANDARD	BOYD	9.5
	CADET SPS 1411	2.5
	HERITAGE N 1301-03	9.3
	VICTOR R 1311-13	5.5
BRIGGS	17T-8610	5.5
	T-8612	5.5
CENTRAL BRASS	3033	3.0
CHASE BRASS	188.355	10.0
CHICAGO FAUCET	620 FC	2.75
	Brown 620-B	8.0
CITADEL	C2209	2.75
CRANE	9-221	3.0
	9-238	5.5
	9-250	8.0
	9-251	8.0
	ECONOMY 8-2564	3.5
	ECONOMY 9-221	3.0
	RAINBEAU 9-238	5.5
	RAINBEAU 8-2556	5.5
	CAPRI 8-2550	8.0
DEARBORN BRASS	DEARBORN	7.5
DELTA	ALL	2.75
DOLE VALVE	2 S	2.0
	3 S	3.0
	4 S	4.0
	2-1S	2.0
	3-1S	2.0
	1	NOT RATED
	3	NOT RATED
DUURMEER	NO. 19	5.6
	NO. 60	9.1
ELJER	E-9115	6.0
FEDERAL HUBER	FEDERAL HUBER	NOT RATED
GYRO BRASS	GYRO-MANY STREAM	NOT RATED
HARVEY MACHINE	HARCRAFT B-2	8.0
INDIANA BRASS	INDIANA BRASS	7.5
KOHLER	K-7325	NOT RATED
	K-7332	NOT RATED
	K-7350	7.0
	K-7370	7.5
LEONARD	HO1	3.0
	HO2	2.0
LOGAN	C-10-2S	2.0
	500 SERIES	2.0
	WIZARD STD. HEAD	2.4 to 3.5
	WIZARD LOW PRES. HEAD	3.5 to 6.0

MANUFACTURER	MODEL	GPM (105°F) NORMAL FLOW	
MAGIC FOUNTAIN	DIAPHRAGM	2.8	
	MAGIC FOUNTAIN	3.0	
MILWAUKEE FAUCET	K-3682 A	3.5	
	CATALINA	3.5	
	PREMIER	3.5	
MOEN	3905	2.75	
	3900 A	2.75	
NOLAND	CITATION NO. 1 DELRIN	4.0	
ONDINE	28446	2.75	
REPCAL BRASS	B-1447	4.0	
	B-1427	5.0	
	HYDRO JET	4.2	
	PRESTO	5.0	
SCOVILLE	1466	7.0	
SEARS	HOMART 2055	10.5	
	HOMART 2080	5.5	
	HOMART 2091	NOT RATED	
SLOAN VALVE	NO. 1 STANDARD ACT-O-MATIC	4.5	
	NO. 2 FINE SPRAY ACT-O-MATIC	3.6	
	NO. 3 NEEDLE SPRAY ACT-O-MATIC	3.0	
	ACT-O-MATIC AC-10	5.5	
SPEAKMAN	1-S-2240	4.5	
	2-S-2240	4.5	
	3-S-2240	2.5	
	S-2250	9.0	
	ANY STREAM NO. 1 S-2250	7.0	
	ANY STREAM NO. 2 S-2250	6.0	
	ANY STREAM NO. 3 SS-2250	8.0	
	ANY STREAM MODEL 1 SS-2250	6.0	
	ANY STREAM MODEL 2 SS-2250	4.0	
	ANY STREAM MODEL 3		
STERLING FAUCET	S-2245	4.5	
	S-194	6.0	
	15-031	6.0	
SURE FLOW BRASS	NO. 35	3.0	
	NO. 36	4.5	
SYMMONS INDUSTRIES	CLEAR-FLO	3.5 to 7.0	
	SUPER-FLO	4.0 to 9.0	
UNIVERSAL RUNDLE	8-1245	4.0	
WRIGHTWAY	BUBBLE STREAM	4.0	

FOOD SERVICE ESTABLISHMENTS

When supplying hot water for food service establishments the water heating system must be adequate to meet the maximum probable demand, regardless of whether the peak period exists for just one hour or much longer. The system must be capable of supplying hot water at two temperatures: 140°F for general purpose water and 180°F for sanitizing water.

Sanitizing water must be maintained at 180°F or higher for the sanitizing rinse of all tableware in restaurants and other food service establishments to insure satisfactory bacteria reduction and to promote rapid air drying. Most health department codes specify a 180°F rinse of tableware. The amount of hot water to be supplied will be governed by meal-serving capacity and the dishwashing equipment being used.

As food service establishments vary considerably in size and dish washing methods range from individual hand washing to the largest continuous-feed automatic dishwashing machines, hot water requirements range from a residential water heater to the largest commercial units.

Additionally, peak demands of dishwashing machines also vary widely and are not generally a consistent factor of the number of meals served during any given period. Table 17 has been formulated to help the architect, engineer, builder or installer to quickly determine the appropriate Bock water heater according to the type of dishwashing being used.

Machine Dishwashing

To make the selection of water heating equipment as simple as possible, Table 17, pages 25-27, lists various models of dishwashing machines and the recommended Bock water heaters needed to meet requirements. Similar requirements of makes not listed in the table can be compared to like requirements that are listed.

Installation Issues

1. A flow pressure of 20 PSI is ideal for a satisfactory rinse. A flow pressure above 20 PSI would cause atomization of the rinse spray and unsatisfactory flushing of washing solution residue from the dishes and tableware. Temperature of the dishes would not be maintained at a level capable of destroying harmful bacteria. An uncontrolled rate of flow would also waste hot water and the heating system would probably be incapable of meeting the unanticipated demand for hot water or maintaining proper temperature. The installation of pressure regulators is strongly advised when the line pressure (flowing) exceeds 20 PSI.
2. The booster providing 180°F water should be located as close to the dishwasher as possible to minimize heat loss in the pipe run, thereby assuring 180°F water at the dishwasher. All hot water piping should be insulated to a 3/4" minimum.

Example: A restaurant serving 200 to 400 meals daily. A Blakeslee Model I-ER dishwasher is specified.

Refer to Table 17 to find the manufacturer of this specified machine and the Bock water heating equipment required to furnish 180°F water. Bock models required to boost the water temperature from 140°F to 180°F are found in Table 17, Section A (if 140°F water is available).

To determine the amount of 140°F general purpose water necessary for the restaurant, refer to Table 17 and size the additional load for the pre-scrapper, pot sinks, etc. If possible, use one water heater to supply all the 140°F general purpose water, plus the 140°F water to be furnished to the dishwasher. Water temperature will be boosted to 180°F by a second water heater. To size, total the general purpose water (for sinks, pot washers, cleaning, etc.) from Table 17 and add this to the total amount of 180°F water required for the specific dishwasher shown in Table 17, Section A.

Example: Small installations

It may be desirable to select one water heater for all 180°F requirements and install a mixing valve to supply 140°F water. (Recirculating, holds temperature more steady, could be on a manual switch.)

Tray-type dishwasher

Tray-type dishwasher sizing can be estimated assuming that the average 60-tray single tank will require 90 GPH of 180°F water. Fifty trays will require 75 GPH of 180°F water, 40 trays 60 GPH. Approximately 1 1/2 times the number of trays per hour determines the gallons of 180°F water needed per hour.

TABLE 16

Water Mixing Valves

Temp. of mixed water	Percentage of hot water automatically mixed with cold water to obtain the desired outlet temperature.						
	COLD WATER SUPPLY						
	40°F	50°F	60°F	70°F	80°F	90°F	100°F
180°F	—	—	—	—	—	—	—
170°F	92.8	92.3	91.7	90.9	90	88.8	87.5
160°F	86	85	83.3	82	80	78	75
150°F	78.5	76	75	73	70	67	62.5
140°F	71	69	67	64	60	55.5	50
130°F	65	61.5	58	54.5	50	44	37.5
120°F	57	54	50	45	40	33	25
110°F	50	46	41.5	35	30	21	12
100°F	43	38	33	27	20	11	11

TABLE 17

MACHINE DISHWASHING REQUIREMENTS

MAKE & MODEL NUMBER	180°F WATER REQUIRED GPH	A BOCK WATER HEATER MODEL TO BOOST EXISTING 140°F WATER TO 180°F				B BOCK WATER HEATER MODEL TO SUPPLY 180°F AT 140°F RISE			
		OIL	ELEC.	GAS	POWER GAS	OIL	ELEC.	GAS	POWER GAS
ADAMATION									
10-20	234	1-51E	1-24KW	1-EZ75-135	1-51PG	1-361E	2-40KW	1-100W-199SD	1-361PG
CA-4 SUPER WASH	288	1-51E	1-30KW	1-EZ75-135	1-51PG	2-73E	2-54KW	1-100W-300SD	2-73PG
SL-1390	294	1-51E	1-30KW	1-EZ75-135	1-51PG	2-73E	2-54KW	1-65W-370SD	2-73PG
CSL-1390	294	1-51E	1-30KW	1-EZ75-135	1-51PG	2-73E	2-54KW	1-65W-370SD	2-73PG
CA,CA-1	417	1-72E	1-45KW	1-EZ80-156	1-72PG	2-361E	3-54KW	1-80W-505SD	2-361PG
CA-2, CA-4	417	1-72E	1-45KW	1-EZ80-156	1-72PG	2-361E	3-54KW	1-80W-505SD	2-361PG
SL-3, CA2M	420	1-72E	1-45KW	1-EZ80-156	1-72PG	2-361E	3-54KW	1-80W-505SD	2-361PG
AMERICAN DISH SERVICE									
AHC, L90-3DW, WC, ET-AH	44	1-51E	1-15KW	1-EZ75-135	1-51PG	1-51E	1-24KW	1-EZ75-135	1-51PG
AC, ETA	51	1-51E	1-15KW	1-EZ75-135	1-51PG	1-51E	1-24KW	1-EZ75-135	1-51PG
AH, L72-3DW, WC	55	1-51E	1-15KW	1-EZ75-135	1-51PG	1-51E	1-24KW	1-EZ75-135	1-51PG
HT-25	61	1-51E	1-15KW	1-EZ75-135	1-51PG	1-51E	1-24KW	1-EZ75-135	1-51PG
A, AFC, AFC-3D, AF-3D (10SEC), L60-3DW, WC, AF, AFC-3D, AF-3D (90 SEC)	68	1-51E	1-15KW	1-EZ75-135	1-51PG	1-51E	1-24KW	1-EZ75-135	1-51PG
AF-B	88	1-51E	1-30KW	1-EZ75-135	1-51PG	2-73E	2-54KW	1-EZ75-135	2-73PG
5AH	101	1-51E	1-15KW	1-EZ75-135	1-51PG	1-72E	1-40KW	1-EZ80-156	1-72PG
ADC-44	120	1-51E	1-15KW	1-EZ75-135	1-51PG	1-72E	2-40KW	1-EZ80-156	1-72PG
5	126	1-51E	1-15KW	1-EZ75-135	1-51PG	1-72E	2-40KW	1-EZ80-156	1-72PG
5AG	168	1-51E	1-24KW	1-EZ80-156	1-51PG	1-72E	2-40KW	1-EZ80-156	1-72PG
BLAKESLEE									
UC-21, D-9	35	1-51E	1-15KW	1-EZ75-135	1-51PG	1-32E	1-24KW	1-EZ75-135	1-51PG
D-8, D8-LT	72	1-51E	1-15KW	1-EZ75-135	1-51PG	1-51E	1-27KW	1-EZ75-135	1-51PG
A-7, B-7, BC7, D7, DC7	117	1-51E	1-15KW	1-EZ75-135	1-51PG	1-72E	2-40KW	1-EZ80-156	1-72PG
DOUBLE D-8, DOUBLE D8-LT, R-L, R-M, R-PL, R-PM, FA-L, FA-M, FA-PL, FA-PM	144							1-EZ75-135	
RA-L, RA-M, RA-PL, RA-PM	282	1-51E	1-30KW	1-EZ75-135	1-51PG	2-73E	2-54KW	1-100W-300SD	2-73PG
F-L, F-M, F-PL, F-PM, R-CC, R-EE, R-LL, R-MM	282	1-51E	1-30KW	1-EZ75-135	1-51PG	2-73E	2-54KW	1-100W-300SD	2-73PG
FA-EE, FA-LL, FA-MM, RA-EE, RA-LL, RA-MM, R-PCC, R-PEE, R-PLL, R-PM, FA-PEE, RA-PLL, RA-PMM, RA-PEE, RA-PLL, RA-PMM, R-EEE, R-LLL, R-MMM, FA-333, FA-LLL, FA-MMM, RA-EEE, RA-LLL, RA-MMM, F-EE, F-LL, F-MM, F-PEE, F-PLL, F-PMM, F-EEE, F-LLL, F-MMM, XF-EE, XF-LL, XF-MM, XF-PEE, XF-PLL, XF-PMM	288	1-51E	1-30KW	1-EZ75-135	1-51PG	2-73PG	2-54KW	1-100W-300SD	2-73PG
2-E, 2-ER, 2-L, 2-LR, 2-M, 2-MR, 3-E, 3-L, 3-M, F2-E, F2-ER, F2-L, FA2-L, F2-LR, FA2-LR, F2-M, FA2-M, F2-MR, FA2-MR, F3-E, FA3-E, F3-L, FA3-L, F3-M, FA3-M	288	1-51E	1-30KW	1-EZ75-135	1-51PG	2-73E	2-54KW	1-100W-300SD	2-73PG
XF-LLL, XF-XMM	360	1-72E	1-40KW	1-EZ80-156	1-72PG	2-361E	3-40KW	1-80W-450SD	—
1-E, 1-ER, 1-L, L-LR, 1-M, 1-MR, F1-E, F1-ER, F1-L, F1-LR, F1-M, F1-MR, XFA2-E, XF2-ER, XFA2-ER, XF2-L, XFA2-L, XF2-LR, FA2-LR, XF2-M, XFA2-M, XF2-MR, XFA2-MR, XF3-E, XFA3-E, XF3-L, XFA3-L, XF3-M, XFA3-M	420	1-72E	1-45KW	1-EZ80-156	1-72PG	2-361E	3-54KW	1-150G-400	3-361PG
XF1-E, XFA1-E, XF1-ER, XFA1-ER, XF1-L, XFA1-L, XF1-LR, XFA1-LR, XF1-M, XFA1-M, XF1-MR, XFA1-MR	720	1-361E	2-36KW	2-EZ75-135	1-361PG	3-361E	5-54KW	1-200G-850	3-361PG
XF-MMM, XF-L, XF-M, XF-PL, XF-PM	720	1-361E	2-36KW	2-EZ75-135	1-361PG	3-361E	5-54KW	1-200G-850	3-361PG
CHAMPION									
U-HB, UH1	33	151E	1-15KW	1-EZ75-135	1-51PG	1-32E	1-24KW	1-EZ75-135	1-51PG
TUW	37	151E	1-15KW	1-EZ75-135	1-51PG	1-32E	1-24KW	1-EZ75-135	1-51PG
U-LD	44	151E	1-15KW	1-EZ75-135	1-51PG	1-32E	1-24KW	1-EZ75-135	1-51PG
D-HB, D-H1, D-LF	66	151E	1-15KW	1-EZ75-135	1-51PG	1-32E	1-24KW	1-EZ75-135	1-51PG
T-6A, T-7A, T-7AC	74	1-51E	1-15KW	1-EZ75-135	1-51PG	1-51E	1-27KW	1-EZ75-135	1-51PG
1-KAB, 1-KACB	107	1-51E	1-15KW	1-EZ75-135	1-51PG	1-72E	1-40KW	1-EZ80-156	1-72PG
44WS, 66WS, 64KB, 64-KPRB	130	151E	1-15KW	1-EZ75-135	1-51PG	1-51E	—	1-EZ75-135	1-51PG
40K Series, 60K Series, PR-96, PR-120	282	1-51E	1-30KW	1-EZ75-135	1-51PG	1-73E	2-54KW	1-100W-300SD	2-73PG
64K Series	348	1-71E	1-36KW	1-EZ80-156	1-71PG	1-361E	3-40KW	1-80W-425SD	—
20K Series, 30K Series	416	1-72E	1-40KW	1-EZ80-156	1-72PG	1-150-400E	3-54KW	1-150G-400	—
UC Series	426	1-72E	1-45KW	1-EZ80-156	1-72PG	3-361E	3-54KW	1-80W-505SD	2-361PG

TABLE 17

MACHINE DISHWASHING REQUIREMENTS

MAKE & MODEL NUMBER	180°F WATER REQUIRED GPH	A BOCK WATER HEATER MODEL TO BOOST EXISTING 140°F WATER TO 180°F				B BOCK WATER HEATER MODEL TO SUPPLY 180°F AT 140°F RISE			
		OIL	ELEC.	GAS	POWER GAS	OIL	ELEC.	GAS	POWER GAS
CHAMPION, cont.									
40KB, 4-PKRB, 44KB, 44-KPRB, KL-44, KL-66	300	1-51E	1-30KW	1-EZ75-135	1-51PG	1-361E	2-54KW	1-65W-370SD	—
54-KB, 54-KBRP	325	1-51E	1-30KW	1-EZ75-135	1-51PG	1-361E	2-54KW	1-65W-370SD	—
UC-C	336	1-51E	1-30KW	1-EZ75-135	1-51PG	1-361E	2-54KW	1-65W-370SD	—
UC-CW	425	1-72E	1-45KW	1-EZ80-156	1-72PG	2-361E	3-54KW	1-65W-625SD	2-361PG
W-6	852	2-71E	—	1-65W-625SD	—	2-150E-400	—	1-250G-1000	—
FOOD EQUIPMENT DIVISION- McGRAW-EDISON									
TKM-20	60	1-51E	1-15KW	1-EZ75-135	1-51PG	1-51E	1-24KW	1-EZ75-135	1-51PG
TKM-27, TKMC-27	116	1-51E	1-15KW	1-EZ75-135	1-51PG	1-72E	1-40KW	1-EZ80-156	2-72PG
TKM-215 thru TKM-324	414	1-72E	1-40KW	1-EZ80-156	72PG	2-361E	3-54KW	1-80W-505SD	2-361PG
TKM-44, TKM-66R	420	1-72E	1-45KW	1-EZ80-156	1-72PG	2-361E	3-54KW	1-80W-505SD	2-361PG
TKM-64 thru TKM-115	624	1-241E	2-30KW	2-EZ75-135	1-241PG	1-200E-650	4-54KW	1-150G-800	—
GENERAL ELECTRIC FOOD SVC. EQPT.									
3T-30B, SK-10B, SK-30B	77	1-51E	1-15KW	1-EZ75-135	1-51PG	1-51E	1-27KW	1-EZ75-135	1-51PG
50-20, SK Series, 50SMT	103	1-51E	1-15KW	1-EZ75-135	1-51PG	1-71E	1-36KW	1-EZ80-156	1-71PG
115-20, 165-20, 225-20, 275-20	282	1-51E	1-30KW	1-EZ75-135	1-51PG	1-361E	2-54KW	1-100W-300SD	2-361PG
SS64B, SS80B, SS86B, SS102B, SS100B, SS116B	300	1-51E	1-30KW	1-EZ75-135	1-51PG	1-361E	2-54KW	1-165W-370SD	1-361PG
SS40B, SS48B, SS62B, SS70B, SS76B, SS84B	426	1-72E	1-45KW	1-EZ80-156	1-72PG	2-361E	3-54KW	1-200G-450	2-361PG
HOBART									
WM Series	68	1-51E	1-15KW	1-EZ75-135	1-51PG	1-51E	1-24KW	1-EZ75-135	1-51PG
UM Series	70	1-51E	1-15KW	1-EZ75-135	1-51PG	1-51E	1-24KW	1-EZ75-135	1-51PG
AM Series, LM-3T3	122	1-51E	1-15KW	1-EZ75-135	1-51PG	1-72E	1-45KW	1-EZ80-156	1-72PG
C-64, CRS-86, FR-64, FRC-64, CPW-100, C-81, CRS-103, FR-81, FRC-81, CWS-103, CPW-117, CS-100, CS-117	282	1-51E	1-30KW	1-EZ75-135	1-51PG	1-361E	2-54KW	1-100W-300SD	1-361PG
FT-200, 300 and 500 Series	348	1-71E	1-36KW	1-EZ80-156	1-71PG	1-361E	3-40KW	1-80W-450SD	—
C-44, CRS-66, CWS-66, CPW-80, C-54CRS-76, FR-54, FRC-54, CWS-76, CPW-90, FT-400 Series	450	1-72E	1-45KW	1-EZ80-156	1-72PG	2-361E	3-54KW	1-200G-450	2-361PG
INSINGER									
45SA5-F1, 45SA5-F2	36	1-51E	1-15KW	1-EZ75-135	1-51PG	1-51E	1-24KW	1-EZ75-135	1-51PG
Ensign 40-2, 45SA	61	1-51E	1-15KW	1-EZ75-135	1-51PG	1-51E	1-24KW	1-EZ75-135	1-51PG
Ensign 40-2, Ensign 60-20M-NSU, 85-20M, 135-20M-NSU, 185-20M-NSU	61	1-51E	1-15KW	1-EZ75-135	1-51PG	1-51E	1-24KW	1-EZ75-135	1-51PG
Commander 18-4, Commander 18-4C, Commander 18-4H	65	1-51E	1-15KW	1-EZ75-135	1-51PG	1-51E	1-24KW	1-EZ75-135	1-51PG
CA-3	70	1-51E	1-15KW	1-EZ75-135	1-51PG	1-51E	1-24KW	1-EZ75-135	1-51PG
Commodore 15, commander 18, 50SA	120	1-51E	1-15KW	1-EZ75-135	1-51PG	1-72E	1-45KW	1-EZ80-135	7-72PG
Admiral 44, Admiral 66-3	210	1-51E	1-24KW	1-EZ75-135	1-51PG	1-361E	2-40KW	1-200G-180	1-361PG
250-20M-NSU	220	1-51E	1-24KW	1-EZ75-135	1-51PG	1-361E	2-40KW	1-EZ100-199	1-361PG
Speeder 65, Speeder 86-3	222	1-51E	1-24KW	1-EZ75-135	1-51PG	1-361E	2-40KW	1-200G-180	1-361PG
Clipper (all)	222	1-51E	1-24KW	1-EZ75-135	1-51PG	1-361E	2-40KW	1-100G-180SD	1-361PG
Century 14	228	1-51E	1-24KW	1-EZ75-135	1-51PG	1-361E	2-40KW	1-100W-250SD	1-361PG
Speeder 5, Speeder 86-1, Clipper 9, Clipper 96-1, Super 8, Super 106-1, Super F-106-1, Master 165-DA-3, 60-DA, 85-DA, 85-DA7, 116DA, 135DA, 165-DA, 185-DA, 225-DA, 250-DA, 275-DA	300	1-51E	1-30KW	1-EZ75-135	1-51PG	1-361E	2-54KW	1-65W-370SD	—
Super 106-2	300	1-51E	1-30KW	1-EZ75-135	1-51PG	1-361E	2-54KW	1-65W-370SD	—
Defender (all)	306	1-51E	1-30KW	1-EZ75-135	1-51PG	1-361E	2-54KW	1-65W-370SD	—
Clipper RC-16 FPW thru RC-21 FPW, Clipper RC16 RPW thru RC-21 RPW, Master RC-18 thru RC-33, Master RC-18 FPW thru RC33 FPW, Master RC-18 RPW thru Master RC-33 RPW	312	1-51E	1-36KW	1-EZ75-135	1-51PG	1-361E	2-54KW	1-65W-370SD	—
Master (all)	360	1-72E	1-40KW	1-EZ80-156	1-72PG	2-361E	3-40KW	1-80W-425SD	—
Admiral 120-5, Admiral 120-7, Admiral 60-2, Admiral 66-2	416	1-72E	1-40KW	1-EZ80-156	1-72PG	2-361E	3-54KW	1-80W-505SD	2-361PG
MiniFlite S-9 thru S-12, Admiral RC-12 FPW thru RC-20 RPW	480	1-73E	1-54KW	1-EZ100-199	1-73PG	2-361E	3-54KW	1-200G-450	2-361PG

TABLE 17

MACHINE DISHWASHING REQUIREMENTS

MAKE & MODEL NUMBER	180°F WATER REQUIRED GPH	A BOCK WATER HEATER MODEL TO BOOST EXISTING 140°F WATER TO 180°F				B BOCK WATER HEATER MODEL TO SUPPLY 180°F AT 140°F RISE			
		OIL	ELEC.	GAS	POWER GAS	OIL	ELEC.	GAS	POWER GAS
Clipper RC-16-EW-2 thru RC-31 RPW-EW-2, Clipper RC-16 RPW-EW-3 thru RC-31 PRW-EW-3, Master RC-18 RPW-EW-3 thru RC-33 RPW-EW-3, Master HRC-	480	1-73E	1-54KW	1-EZ100-199	1-73PG	2-361E	3-54KW	1-65W-625SD	2-361PG
JACKSON									
10A, 10AB, 10APRB, 10APRB-H, 50APR, 50APRB, JV-24A, JV-24AF, JB-24B, JV-24BF		1-51E	1-15KW	1-EZ75-135	1-51PG	1-51E	1-24KW	1-EZ75-135	1-51PG
JL-100A, JL100G, JL-100, JL100PRB, JL-100PR		1-51E	1-15KW	1-EZ75-135	1-51PG	1-51E	1-72E	1-EZ80-156	1-72PG
J-44, SJF-44, 39C, 44-C		1-72E	1-40KW	1-EZ80-156	1-72PG	2-361E	3-54KW	1-80W-505SD	2-361PG
4-A, DJF-48, 4-ARD, 6-A, DJF-60, 6-ARD, ROTO DR JR, DJF-64, 1323 thru 2673 (Suffix "B" models have integral booster)		1-51E	1-30KW	1-EZ75-135	1-51PG	2-73E	2-54KW	1-EZ75-135	2-73PG
JP-24 Series	26	1-51E	1-15KW	1-EZ75-135	1-51PG	1-51E	1-24KW	1-EZ75-135	1-51PG
24LT Series	29	1-51E	1-15KW	1-EZ75-135	1-51PG	1-51E	1-24KW	1-EZ75-135	1-51PG
200 Series	52	1-51E	1-15KW	1-EZ75-135	1-51PG	1-51E	1-24KW	1-EZ75-135	1-51PG
Temp Star, SDS	52	1-51E	1-15KW	1-EZ75-135	1-51PG	1-51E	1-24KW	1-EZ75-135	1-51PG
Conservor II	60	1-51E	1-15KW	1-EZ75-135	1-51PG	1-51E	1-24KW	1-EZ75-135	1-51PG
Conservor I	111	1-51E	1-15KW	1-EZ75-135	1-51PG	1-72E	2-40KW	1-EZ80-156	1-72PG
10 Series	234	1-51E	1-24KW	1-EZ75-135	1-51PG	1-361E	2-40KW	1-100W-250SD	1-361PG
AJ-44, AJ-66, AJ-80 Vision Series	234	1-51E	1-24KW	1-EZ75-135	1-51PG	1-361E	2-40KW	1-100W-250SD	1-361PG
MOYER DIEBEL									
501LT, 501HT									
MD-18 Series									
MH6-L, MH60									
501HTN	37	1-51E	1-15KW	1-EZ75-135	1-51PG	1-51E	1-24KW	1-EZ75-135	1-51PG
MH6N	66	1-51E	1-15KW	1-EZ75-135	1-51PG	1-51E	1-24KW	1-EZ75-135	1-51PG
STERO									
SF-1RA, SF-2RA, SF-2DRA, SDRA, SD-2RA	103	1-51E	1-15KW	1-EZ75-135	1-51PG	1-71E	1-36KW	1-EZ80-156	1-51PG
SCT-44, SCT44-10, SCT-76S, SCT-76SC, SC-1-SCT-44, SC-1-SCT-44-10, SC-1-SCT-54, SC-2-4, SC-6-4, SC-1-2-4, SC-1-6-4, SC-5-6-4	417	1-51E	1-40KW	1-EZ80-156	1-72PG	2-361E	3-54KW	1-80W-505SD	1-51PG
SCT-64, SCT-76, SCT-80, SCT-94, SCT-94S, SCT-95SC, SCT-108S, SCT-108SC, SCT-108, SCT-120, SCT-120SM, SCT-120S, SCT-120SC, SCT-05SM, SC-1-SCT-64, SC-1, SC-76, SCT-80, SCT-94, SCT-108, SCT-120, SC-5, SCT-64	277	1-51E	1-27KW	1-EZ75-135	1-51PG	1-241E	3-40KW	1-100W-300SD	2-51PG
SC-2-3-4, SC-6-3-4, SC-2-7-4, SCT-44, SC-3-4, SCT-44-10SC-3-4, SCT-54SC-3-4, SC-1-2-7-4, SC-1-6-3-4, SC-5-2-3-4, SC1-6-7-4, SC5-6-3-4, SC-5-2-7-4, SCT-76S-SC-3-4, SCT-44SC-1-3-4, SCT-44-10SC-1-3-4, SCT-54SC1-3-4	295	1-51E	1-30KW	1-EZ75-135	1-51PG	1-361E	3-54KW	1-65W370SD	1-361PG
SCT-76SM, STPC-15, STPEC-18, STPEC-19, STPEC-19PS, STPEC-20, STPC-22, STPEC-24, STPEC-24D, STPEC-26, STPEC-26D	330	1-72E	1-36KW	1-EZ75-135	1-71PG	1-361E	2-54KW	1-65W-399SD	1-361PG
STPCW-15 thru STPCW-26	390	1-72E	1-40KW	1-EZ80-156	1-72PG	2-361E	3-40KW	1-80W-505SD	—
STPC-10, STPC-12HS, STPC-12PS	465	1-73E	1-54KW	1-EZ100-199	1-73PG	1-200E-450	4-54KW	1-200G-450	—
STPCW-10, STPCW-12HS, STPCW-12PS, STPCW-15HS, STPCW-15PS	576	1-241E	2-30KW	—	1-241PG	1-150E-600	4-54KW	1-200G-600	—
VULCAN-HART									
CU-16BTA, R-16BTA, 3D20T, CD20T	120	1-51E	1-15KW	1-EZ75-135	1-51PG	1-72E	1-45KW	1-EZ80-156	—
A-44 thru A-54	480	1-73E	1-54KW	1-EZ100-199	1-73PG	2-361E	3-54KW	1-65W-625SD	—
A-64 thru A-98	390	1-72E	1-40KW	1-EZ80-156	1-72PG	2-361E	3-40LW	1-80W-505SD	—
CP-3 Series, HP-3 Series, CP-2 Series	420	1-72E	1-40KW	1-EZ80-156	1-72PG	2-361E	3-54KW	1-EZ100-199	—
WELLS									
AD-20 Series	102	1-51E	1-15KW	1-EZ75-135	1-51PG	1-72E	1-36KW	1-EZ80-156	—
AD-64, AD-80, PC-19, PC-26	300	1-51E	1-30KW	1-EZ75-156	1-51PG	2-51E	2-45KW	1-65W-370SD	—
AD-44, PC-12	480	1-73E	1-54KW	1-EZ100-199	1-73PG	2-361E	3-54KW	1-65W-625SD	—

SELF-SERVICE AND COMMERCIAL LAUNDRIES

Self-Service Laundries

Self-service laundries typically require 2 1/2 gallons of water per pound of laundry, which should be adequate for hot water storage plus a recovery capacity equal to the hourly demand of automatic washing machines. Although hot water demands will not be uniform, there may be times when all machines would be in operation simultaneously – most likely to occur on weekdays or at night.

This possible one-hour peak demand should always be given serious consideration when sizing for self-service laundry hot water requirements.

Bock uses a calculation of two cycles per hour. This number – multiplied by the number of machines by the gallons of hot water used by each machine – gives the amount of hot water used per hour. This known GPH, along with temperature of water required, will determine the capacity needed.

Consult manufacturers for sizes of machines. Hot water requirements for a self-service laundry are determined through the following steps:

1. From the rating plate on the machine or from the manufacturer's literature, find hot water usage in GPH for each automatic washer.
 - A. Few self-service laundries use the pre-wash soak cycle. This factor should be ascertained, however, and the gallonage used in the soak cycle subtracted from the unit rating.
 - B. If the rating for each washer cannot be found, use 25 GPH for each unit (if one cycle per hour).
2. Add together all the individual washer requirements for the maximum hourly demand.
3. From Tables 33-50, pages 58 - 75, determine the num-

ber of high volume water heaters required to supply the laundry's probably hourly demand.

Example: Laundry with 30 washers

Each washer has a capacity of 26 GPH of 140° F water. Laundry operates on one-hour peak demand.

Total Hourly Usage: $30 \times 26 = 780$ gallons @ 140° F

Using Tables 43-44, pages 68 - 69, Bock models EZ80-156, 190PG, and 72E would satisfy demand. At a 90°F rise, the following sizing recommendations can be made:

1) (3)-EZ80-156 units can provide:

Recovery: 3×212 GPH = 636 GPH

Usable Storage: 3×80 gal. $\times 0.8 = 192$ gal.

Total 1-hr delivery = 636 GPH + 192 gal. = **828 gallons**

2) (3)-190PG units can provide:

Recovery: 3×191 GPH = 573 GPH

Usable Storage: 3×113 gal. $\times 0.8 = 271$ gal.

Total 1-hr delivery = 573 GPH + 271 gal. = **844 gallons**

3) (3)-72E units can provide:

Recovery: 3×212 GPH = 636 GPH

Usable Storage: 3×67 gal. $\times 0.8 = 161$ gal.

Total 1-hr delivery = 636 GPH + 161 gal. = **797 gallons**

Note : This formula is for average conditions which include an occasional peak demand. When all machines are used constantly, the preceding formula must be doubled (as - suming a half-hour cycle per machine).

Commercial Laundries

The best way to determine the cycle of hot water needs of a commercial laundry is to contact the equipment manufacturer. If this cannot be done, assumed three gallons of hot water per one pound of laundry with half the required water being hot. Bock recommends 160°F for this water.

SWIMMING POOLS, HOT TUBS AND BAPTISTRIES

Size a hot tub based on its gallon capacity. Obtain this quantity from either the manufacturer or by using steps 1 and 2 of the Swimming Pool instruction section on page 28. Determine how long it will take to fill the tub.

With these known factors, size the water heater using Deliverability Tables 33-50, pages 58 - 75. These tables show the capability of different types of Bock water heaters for a given length of time at a desired temperature.

To use these tables, find the temperature rise, which depends on water temperature norms for the geographical region:

Northern Tier States – 45°F to 55 °F

Central Tier States – 55 °F to 60 °F

Southern Tier States – 65°F to 75 °F

To determine the temperature rise, subtract the desired temperature from the norm for the area.

Example: 125°F water in a South Tier state. Result: 125°F minus 60 °F to 65 °F temperature rise.

Refer to Table 37-38, pages 62-63 to find the maximum delivery in gallons (Use Tables 39-40, pages 64-65 for a 65°F rise).

Example: To fill a 120-gallon hot tub in 15 minutes, look down the 15 MINUTE column to 120 gallons or higher. Then move left across that space to find the correct Bock model water heater. This example requires a 72PG, EZ80-156, or 72E. Use this same method to size a baptistry.

Note: Aerated hot tubs have approximately 50% greater heat loss than standard tubs. To maintain temperature, Bock recommends adding half of the total heat loss to the sizing and increasing the input by 50%.

The first criterion is the maximum temperature rise in degrees Fahrenheit (°F), for initial heat-up (Delta T) to establish the desired pool temperature. The temperature rise is determined by the known desired pool temperature and then by the ambient air conditions at the time the pool water is initially heated.

The second criterion is the time allowed for the initial heating of the pool or spa water (for example; 24 or 48 hours).

The third criterion is the size of the swimming pool or spa. The water heater must be sized large enough for initial heat-up within the desired time frame.

From these criteria, calculate the hourly BTU input. BTUH input is the basis used to find the correct Bock water heater model. After the BTUH calculation has been determined, refer to Tables 33-50, pages 58 - 75 to find the exact Bock water heater to fit the requirements.

Steps to finding the BTU hourly input:

1. Cubic feet - length X width X average depth.
2. Gallons - cubic feet X 7.5.
3. Hourly BTU input = gallons X factor.

A. Factor is found in Table 18, this page, by noting the hours desired for heating the swimming pool or spa water, plus the temperature rise.

B. To find the temperature rise, first decide the ideal water temperature for the pool or spa, then subtract the yearly average outdoor temperature for the month pool heating will begin. Call the local weather station to find the yearly average temperature for the area.

Example: Swimming pool is 40' x 18' x 5' = 3600 cubic feet. 3600 X 7.5 = 27,000 gallon capacity. Need 48 hours to heat swimming pool. Average water temperature at initial heat-up is 60°F. Desire 80°F water temperature in pool. 80 - (minus) 60 = 20°F rise. Factor = 5 (with 48 hours heating time and 20°F rise) refer to Table 18. BTUH = 27,000 gallons X 5 = 135,000 BTUH input. A Bock Model 5IPG or a 5IE would be appropriate for this example. Refer to Tables 33-50, pages 58 - 75.

In a swimming pool or spa installation, the major consideration when using a storage-type water heater is the prevention of condensation inside the unit.

Condensation is held to a minimum when the temperature in the water heater is maintained above 120°F. To do this, use a bypass, which will increase the life of the water heater tank and combustion chamber appreciably (water temperature higher than 120°F has no other function).

Only one-fourth of the water goes through the water heater. The remaining three-fourths is bypassed around the water heater. The desired water temperature is maintained by adjusting one valve. The bypass valve should be left open far enough to maintain water temperature in the tank at 120°F or higher.

The temperature of the water after the bypass is increased only 2°F to 5°F, and is ideal for reintroducing back into the pool. See Figure 20, page 29. Also see Figure 27, page 35, for hookup drawing.

NOTE: Install only on non-combustible flooring.

FIGURE 20: Piping Diagram

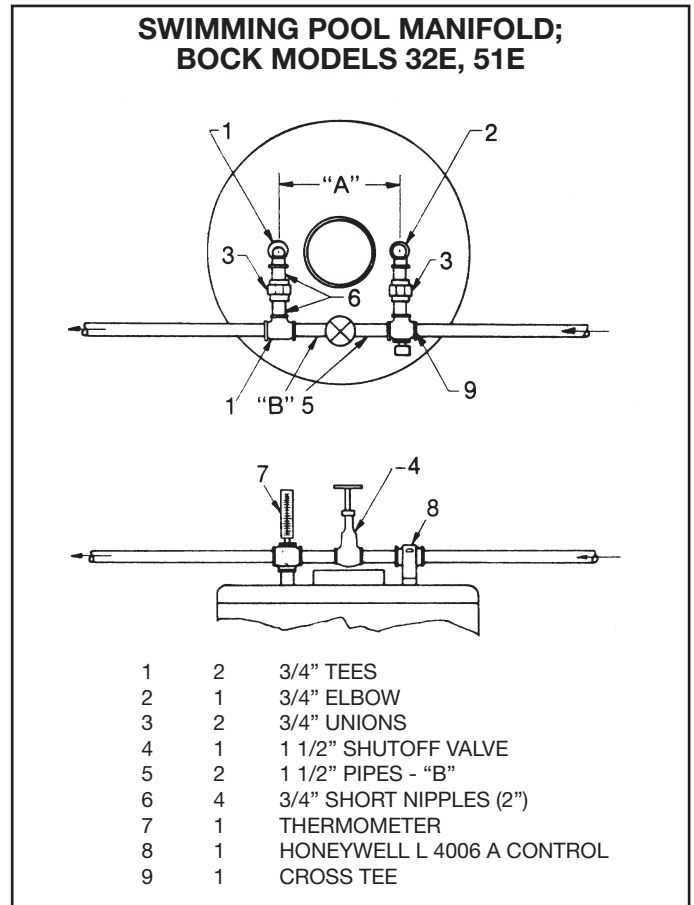

Note: If chlorinated water is used, the dip tube must be removed from the heater and the drain valve must be used as the inlet.

TABLE 18

Sizing swimming pools, hot tubs, baptistries

HEATING TIME IN HOURS	Factors					
	20°F RISE	25°F RISE	30°F RISE	40°F RISE	50°F RISE	60°F RISE
1	250	300	375	500	625	720
2	120	150	180	250	300	360
3	80	100	120	160	200	240
4	60	75	90	120	150	180
5	48	60	72	96	120	144
6	40	50	60	80	100	120
7	34	42	52	68	85	102
8	30	37	45	60	75	90
9	26	32	39	52	65	78
10	24	30	36	48	60	72
12	20	25	30	40	50	60
24	10	12.5	15	20	25	30
48	*5	*6.3	*7.5	10	12.5	15
72	3.4	4.25	5.1	6.8	8.5	10.2
96	2.5	3.0	3.75	5.0	6.25	7.5

* Most commonly used

Note: For swimming pools, heating periods of 48 to 72 hours are usually acceptable. For baptistries, the heating period is typically five to 12 hours.