



EZFIT

76,000 BTU/HR Power Direct Vented Commercial Gas Water Heaters 3" or 4" PVC, ABS or CPVC Venting

- ◆ **Five-year limited tank warranty**
- ◆ Vertical or horizontal plastic vent
- ◆ Room or outside combustion air
- ◆ Zero clearance to combustibles
- ◆ 75 and 100 gallon capacities
- ◆ Self-diagnostic control
- ◆ 120°F to 180°F settable temperature
- ◆ Top: 1" Hot/Cold domestic hot water connections
- ◆ Side: 1" Hot/Cold space heating connections
- ◆ Natural gas or propane burner
- ◆ Glass-fused-to-steel tank interior
- ◆ Two magnesium anode rods
- ◆ 2" Non-CFC foam insulation
- ◆ Factory installed T&P relief valve
- ◆ Powder coated steel exterior
- ◆ Brass drain valve



Turboflue[®]

heat exchanger

- ◆ Energy-Saving Turbofins conduct more heat into water
- ◆ Robust single-flue design yields a stronger, more durable tank





This product is available from:

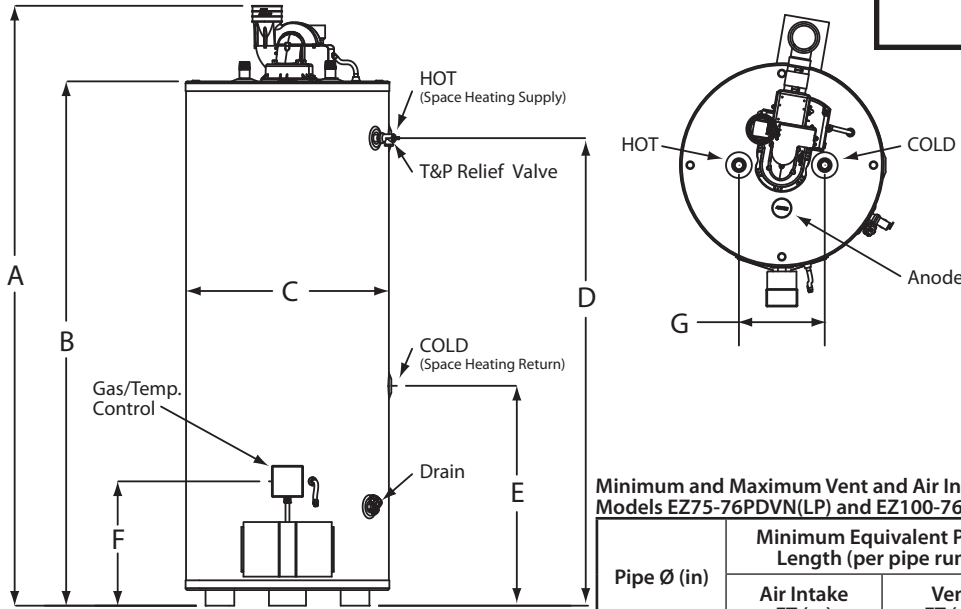

Minimum and Maximum Vent and Air Intake Pipe Lengths (Two-Pipe Terminations)
Models EZ75-76PDVN(LP) and EZ100-76PDVN(LP)

Pipe Ø (in)	Minimum Equivalent Pipe Length (per pipe run)		Maximum Equivalent Pipe Length (per pipe run)*	
	Air Intake FT (m)	Vent FT (m)	Air Intake FT (m)	Vent FT (m)
3	5 (1.52)	12 (3.66)	55 (16.76)	55 (16.76)
4	5 (1.52)	12 (3.66)	85 (25.91)	85 (25.91)

*Note: For Concentric Terminations, subtract 10 feet from Maximum Equivalent Pipe Length.
Equivalent straight pipe length of 90° elbow equals 5 feet.

Model	Storage GAL (L)	Rated Input BTU/HR (kW)	Recovery @ 100°F Rise GAL/HR (L/HR)	1ST Hr. Del. @ 100°F Rise GAL (L)	Dimensions in Inches (cm)						Inlet Conn. Dia. NPT	Outlet Conn. Dia. NPT	Aux. Conn. Dia. NPT	Gas Conn. Dia. NPT	Shipping Weight LBS (kg)	
					A	B	C	D	E	F						G
EZ 75-76PDVN	75 (283.91)	76,000 (22.27)	74 (280.12)	135 (511.03)	76.88 (195.28)	67.25 (170.82)	26.00 (66.04)	60.00 (152.40)	28.19 (71.60)	16.00 (40.64)	11.00 (27.94)	1.00	1.00	1.00	0.50	427 (193.68)
EZ 100-76PDVN	100 (379.54)	76,000 (22.27)	74 (280.12)	155 (587.74)	76.88 (195.28)	67.25 (170.82)	28.00 (71.12)	60.00 (152.40)	28.19 (71.60)	16.00 (40.64)	11.00 (27.94)	1.00	1.00	1.00	0.50	530 (240.40)

For LP models change suffix "N" to "LP"

Working Pressure: 150 psi (1034 kPa)

Test Pressure: 300 psi (2068 kPa)

For natural gas: manifold pressure = 4" w.c. (1.00 kPa); Inlet pressure range = 5 - 14" w.c. (1.25 - 3.49 kPa)

For propane gas: manifold pressure = 10" w.c. (2.49 kPa); Inlet pressure range = 11 - 14" w.c. (2.74 - 3.49 kPa)

T&P valve factory installed

All Bock products meet or exceed current ASHRAE standards.

These products are design certified by UL (Underwriters Laboratories) and meet ANSI Z21.10.3/CSA 4.3 requirements for operation up to 180°F (82°C).

Approved for use as direct vent automatic storage water heater.

Warning: Installation should be in accordance with all national and/or local codes. In the absence of local codes, refer to NFPA 54 and/or CSA B149.1.

Caution: The recommended maximum hot water temperature setting for normal residential use is 120°F (49°C). Bock recommends a tempering valve or anti-scald valve be installed and used according to the manufacturer's directions to prevent scalding.



www.bockwaterheaters.com
110 South Dickinson Street, Madison, Wisconsin 53703
Toll Free 800-794-2491 • Phone 608-257-2225 • Fax 608-257-5304

