



## COMMERCIAL ATMOSPHERIC GAS WATER HEATERS

**FEATURING... Environmentally friendly Low NOx burners as standard equipment to reduce greenhouse gases and air pollution**

**FIVE-YEAR LIMITED WARRANTY**  
*the industry's finest commercial protection*

- ◆ 75, 80, and 100 gallon capacities
- ◆ 135,000 to 199,000 BTUH
- ◆ Low NOx certified to not exceed 40ng/J
- ◆ Natural gas or propane burner
- ◆ 120°F to 180°F adjustable electronic thermostat
- ◆ Electronic ignition
- ◆ Automatic damper
- ◆ Water jet sediment reduction side inlet
- ◆ Clean out port
- ◆ Optional leg extension kit lifts water heater to NSF-5 standard



**Turboflue<sup>®</sup>**  
heat exchanger

- ◆ Energy-Saving Turbofins conduct more heat into water
- ◆ Robust single-flue design yields a stronger, more durable tank





This product is available from:

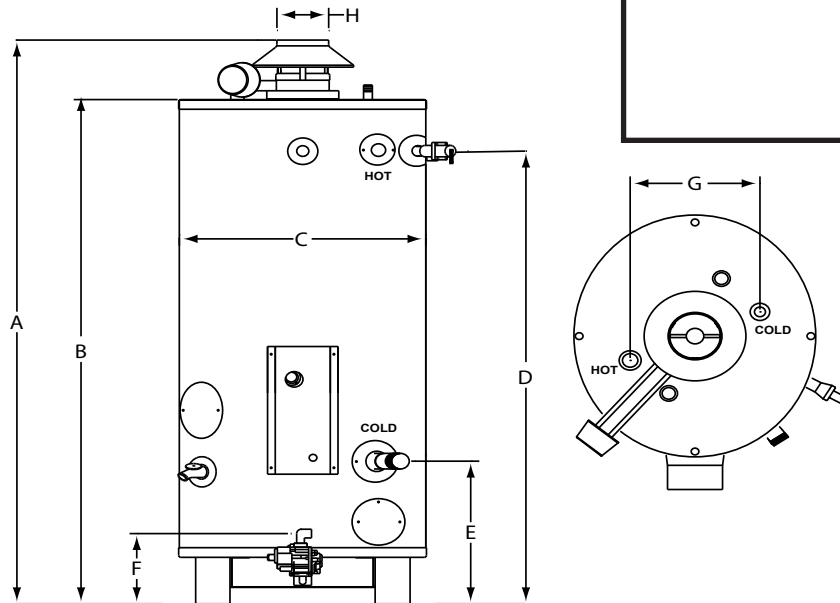

Model	Storage GAL (L)	Rated Input BTU/HR (kW)	Recovery @ 100°F Rise GAL/HR (L/HR)	1st Hr. Del. @ 100°F Rise GAL (L)	Dimensions in Inches (cm)								Aux. Conn. Dia. NPT	Inlet Conn. Dia. NPT	Outlet Conn. Dia. NPT	Gas Conn. Dia. NPT	Shipping Weight LBS (kg)
					A	B	C	D	E	F	G	H					
EZ75-135N	67 (253.62)	135,000 (39.56)	130 (492.10)	183 (692.73)	73.25 (186.06)	65.50 (166.37)	26.00 (66.04)	58.25 (147.96)	20.00 (50.80)	9.00 (22.86)	16.00 (40.64)	6.00 (15.24)	1.50	1.50	1.50	0.50	410 (185.97)
EZ80-156N	80 (302.83)	156,000 (45.72)	150 (567.81)	214 (810.08)	73.25 (186.06)	65.50 (166.37)	26.00 (66.04)	58.50 (148.59)	18.00 (45.72)	9.00 (22.86)	16.00 (40.64)	6.00 (15.24)	1.50	1.50	1.50	0.50	440 (199.58)
EZ80-199N	80 (302.83)	199,000 (58.32)	191 (723.01)	255 (965.28)	73.00 (185.42)	65.25 (165.74)	28.00 (71.12)	58.50 (148.59)	18.00 (45.72)	9.00 (22.86)	16.00 (40.64)	6.00 (15.24)	1.50	1.50	1.50	0.50	500 (266.80)
EZ100-199N	100 (378.54)	199,000 (58.32)	191 (723.01)	271 (1,025.85)	70.75 (179.71)	63.00 (160.02)	31.50 (80.01)	54.75 (139.07)	18.00 (45.72)	9.00 (22.86)	19.00 (48.26)	6.00 (15.24)	1.50	1.50	2.00	0.50	655 (297.10)

For LP models change suffix "N" to "LP"

**Working Pressure:** 150 psi (1034 kPa)

**Test Pressure:** 300 psi (2068 kPa)

**Standard Voltage required:** 120V, 60Hz, 1P

For natural gas: manifold pressure = 3.5" w.c. (0.87 kPa); Inlet pressure range = 5 - 14" w.c. (1.25-3.49 kPa)

For propane gas: manifold pressure = 10" w.c. (2.49 kPa); Inlet pressure range = 12 - 14" w.c. (2.99-3.49 kPa)

**T&P valve factory installed**

All Bock products meet or exceed current ASHRAE standards.

These products are design certified by UL (Underwriters Laboratories) and meet ANSI Z21.10.3/CSA 4.3 requirements for operation up to 180°F (82°C).

Approved for use as an automatic circulating tank water heater or automatic storage water heater.

**Warning:** Do not install on combustible flooring. Installation should be in accordance with all national and/or local codes. In the absence of local codes, refer to NFPA 54 or ANSI Z21.10.3

**Caution:** The recommended maximum hot water temperature setting for normal residential use is 120°F (49°C). Bock recommends a tempering valve or anti-scald valve be installed and used according to the manufacturer's directions to prevent scalding.



[www.bockwaterheaters.com](http://www.bockwaterheaters.com)  
**110 South Dickinson Street, Madison, Wisconsin 53703**  
**Toll Free 800-794-2491 • Phone 608-257-2225 • Fax 608-257-5304**

